

Features

- 3.3 V V_{CC} with 5 V tolerant inputs
- Third Generation Field-Programmable Gate Arrays
 - Select-RAM™ memory: on-chip ultra-fast RAM with synchronous write and dual port options
 - Abundant flip-flops and flexible function generators
 - Dedicated high-speed carry logic
 - Wide edge decoders on each edge
 - Internal 3-state bus capability
- Almost twice the routing capacity of XC4000E devices
 - Buffered interconnect for maximum speed
 - New latch capability in CLBs
 - Flexible high-speed clock networks
 - 8 global low-skew clock or signal networks
 - Optional multiplexer device outputs
- System Performance to 80 MHz
- Systems-Oriented Features
 - Fully 3.3-V PCI Compliant
 - IEEE 1149.1-compatible boundary scan logic
 - Individually programmable output slew rate
 - Programmable input pull-up or pull-down resistors
 - 12 mA sink current
 - Unlimited reprogrammability
- Readback Capability

Description

The XC4000XL devices extend the popular XC4000E family over the broadest gate capacity range, from 3,000 to 180,000 gates, with up to 7,168 flip-flops. XC4000XL devices are structurally and functionally a superset of the XC4000E family, offering additional and improved signal and clock routing resources, and a new, much faster, byte-wide express configuration mode. XC4000XL devices operate from a 3.3 V supply, but their inputs are 5 V tolerant.

All XC4000-Series devices are implemented with a regular, flexible, programmable architecture of Configurable Logic Blocks (CLBs), interconnected by a power hierarchy of versatile routing resources, and surrounded by a perimeter of programmable Input/Output Blocks (IOBs). They have generous routing resources to accommodate the most complex interconnect patterns.

The devices are customized by loading configuration data into internal memory cells. The FPGA can either actively read its configuration data from an external serial or byte-parallel PROM (master modes), or the configuration data can be written into the FPGA from an external device (slave, peripheral and express modes).

All XC4000-Series FPGAs are supported by powerful and sophisticated software, covering design from schematic or behavioral entry, floorplanning, simulation, automatic block placement and routing of interconnects, to the creation, downloading, and readback of the configuration bit stream.

XC4000XL Family of Field Programmable Gate Arrays

Device	Max. Logic Gates (No RAM)	Max. RAM Bits (No Logic)	Typical Gate Range (Logic and RAM)*	CLB Matrix	Total Logic Blocks	Number of Flip-Flops	Max.Decode Inputs per side	Max. User I/O
XC4002XL	2,000	2,048	1,500 - 3,000	8 x 8	64	256	24	64
XC4005XL	5,000	6,272	3,000 - 9,000	14 x 14	196	616	42	112
XC4010XL	10,000	12,800	7,000 - 20,000	20 x 20	400	1,120	60	160
XC4013XL	13,000	18,432	10,000 - 30,000	24 x 24	576	1,536	72	192
XC4020XL	20,000	25,088	13,000 - 40,000	28 x 28	784	2,016	84	224
XC4028XL	28,000	32,768	18,000 - 50,000	32 x 32	1,024	2,560	96	256
XC4036XL	36,000	41,472	22,000 - 65,000	36 x 36	1,296	3,168	108	288
XC4044XL	44,000	51,200	27,000 - 80,000	40 x 40	1,600	3,840	120	320
XC4052XL	52,000	61,952	33,000 - 100,000	44 x 44	1,936	4,576	132	352
XC4062XL	62,000	73,728	40,000 - 130,000	48 x 48	2,304	5,376	144	384
XC4085XL	85,000	100,352	55,000 - 180,000	56 x 56	3,136	7,168	168	448

* Max values of Typical Gate Range include 20-30% of CLBs used as RAM

XC4000XL Switching Characteristics

Definition of Terms

In the following tables, some specifications may be designated as Advance or Preliminary. These terms are defined as follows:

Advance: Initial estimates based on simulation and/or extrapolation from other speed grades, devices, or families. Values are subject to change. Use as estimates, not for production.

Preliminary: Based on preliminary characterization. Further changes are not expected.

Unmarked: Specifications not identified as either Advance or Preliminary are to be considered final.

All specifications subject to change without notice.

Additional Specifications

Except for pin-to-pin input and output parameters, the a.c. parameter delay specifications included in this document are derived from measuring internal test patterns. All specifications are representative of worst-case supply voltage and junction temperature conditions. The parameters included are common to popular designs and typical applications.

Absolute Maximum Ratings

Symbol	Description		Units
V_{CC}	Supply voltage relative to GND	-0.5 to 4.0	V
V_{IN}	Input voltage relative to GND (Note 1)	-0.5 to 5.5	V
V_{TS}	Voltage applied to 3-state output (Note 1)	-0.5 to 5.5	V
V_{CCt}	Longest Supply Voltage Rise Time from 1 V to 3V	50	ms
T_{STG}	Storage temperature (ambient)	-65 to +150	°C
T_{SOL}	Maximum soldering temperature (10 s @ 1/16 in. = 1.5 mm)	+260	°C
T_J	Junction temperature	Ceramic packages	+150 °C
		Plastic packages	+125 °C

- Notes:
1. Maximum DC overshoot or undershoot above V_{CC} or below GND must be limited to either 0.5 V or 10 mA, whichever is easier to achieve. During transitions, the device pins may undershoot to -2.0 V or overshoot to +7.0 V, provided this over- or undershoot lasts less than 10 ns and with the forcing current being limited to 200 mA.
 2. Stresses beyond those listed under Absolute Maximum Ratings may cause permanent damage to the device. These are stress ratings only, and functional operation of the device at these or any other conditions beyond those listed under Operating Conditions is not implied. Exposure to Absolute Maximum Ratings conditions for extended periods of time may affect device reliability.

Recommended Operating Conditions

Symbol	Description		Min	Max	Units
V_{CC}	Supply voltage relative to GND, $T_J = 0^\circ\text{C}$ to $+85^\circ\text{C}$	Commercial	3.0	3.6	V
	Supply voltage relative to GND, $T_J = -40^\circ\text{C}$ to $+100^\circ\text{C}$	Industrial	3.0	3.6	V
V_{IH}	High-level input voltage		50% of V_{CC}	5.5	V
V_{IL}	Low-level input voltage		0	30% of V_{CC}	V
T_{IN}	Input signal transition time			250	ns

- Notes:
- At junction temperatures above those listed as Operating Conditions, all delay parameters increase by 0.35% per °C.
 - Input and output measurement threshold is ~50% of V_{CC} .

DC Characteristics Over Recommended Operating Conditions

Symbol	Description	Min	Max	Units	
V_{OH}	High-level output voltage @ $I_{OH} = -4.0$ mA, V_{CC} min (LVTTTL)	2.4		V	
	High-level output voltage @ $I_{OH} = -500$ μ A, (LVCMOS)	$90\% V_{CC}$		V	
V_{OL}	Low-level output voltage @ $I_{OL} = 12.0$ mA, V_{CC} min (LVTTTL) (Note 1)		0.4	V	
	Low-level output voltage @ $I_{OL} = 1500$ μ A, (LVCMOS)		$10\% V_{CC}$	V	
V_{DR}	Data Retention Supply Voltage (below which configuration data may be lost)	2.5		V	
I_{CCO}	Quiescent FPGA supply current (Note 2)		5	mA	
I_L	Input or output leakage current	-10	+10	μ A	
C_{IN}	Input capacitance (sample tested)				
		BGA, SBGA, PQ, HQ, MQ packages		10	pF
		PGA packages		16	pF
I_{RPU}	Pad pull-up (when selected) @ $V_{in} = 0$ V (sample tested)	0.02	0.25	mA	
I_{RPD}	Pad pull-down (when selected) @ $V_{in} = 3.6$ V (sample tested)	0.02	0.15	mA	
I_{RLL}	Horizontal Longline pull-up (when selected) @ logic Low	0.3	2.0	mA	

Note 1: With up to 64 pins simultaneously sinking 12 mA.

Note 2: With no output current loads, no active input or Longline pull-up resistors, all I/O pins Tri-stated and floating.

XC4000XL Global Buffer Switching Characteristic Guidelines

Testing of the switching parameters is modeled after testing methods specified by MIL-M-38510/605. All devices are 100% functionally tested. Internal timing parameters are derived from measuring internal test patterns. Listed below are representative values where one global clock input drives one vertical clock line in each accessible column, and where all accessible IOB and CLB flip-flops are clocked by the global clock net.

When fewer vertical clock lines are connected, the clock distribution is faster; when multiple clock lines per column are driven from the same global clock, the delay is longer. For more specific, more precise, and worst-case guaranteed data, reflecting the actual routing structure, use the values provided by the static timing analyzer (TRCE in the Xilinx Development System) and back-annotated to the simulation netlist. These path delays, provided as a guideline, have been extracted from the static timing analyzer report. All timing parameters assume worst-case operating conditions (supply voltage and junction temperature). Values apply to all XC4000XL devices and are expressed in nanoseconds unless otherwise noted.

XC4000XL Global Low Skew Buffer to Clock K

Description	Symbol	Speed Grade Device	All	-3	-2	-1	-09	-08	Units
			Min	Max	Max	Max	Max	Max	
Delay from pad through GLS buffer to any clock input, K	T _{GLS}	XC4002XL	0.3	2.1	1.8	1.6	1.5		ns
		XC4005XL	0.4	2.7	2.3	2.0	1.9		ns
		XC4010XL	0.5	3.2	2.8	2.4	2.3		ns
		XC4013XL	0.6	3.6	3.1	2.7	2.6	2.3	ns
		XC4020XL	0.7	4.0	3.5	3.0	2.9		ns
		XC4028XL	0.9	4.4	3.8	3.3	3.2		ns
		XC4036XL	1.1	4.8	4.2	3.6	3.5	3.1	ns
		XC4044XL	1.2	5.3	4.6	4.0	3.9		ns
		XC4052XL	1.3	5.7	5.0	4.5	4.4		ns
		XC4062XL	1.4	6.3	5.4	4.7	4.6	4.0	ns
XC4085XL	1.6	7.2	6.2	5.7	5.5		ns		

XC4000XL Global Buffer Switching Characteristic Guidelines

Testing of the switching parameters is modeled after testing methods specified by MIL-M-38510/605. All devices are 100% functionally tested. Internal timing parameters are derived from measuring internal test patterns. Listed below are representative values where one global clock input drives one vertical clock line in each accessible column, and where all accessible IOB and CLB flip-flops are clocked by the global clock net.

When fewer vertical clock lines are connected, the clock distribution is faster; when multiple clock lines per column are driven from the same global clock, the delay is longer. For more specific, more precise, and worst-case guaranteed data, reflecting the actual routing structure, use the values provided by the static timing analyzer (TRCE in the Xilinx Development System) and back-annotated to the simulation netlist. These path delays, provided as a guideline, have been extracted from the static timing analyzer report. All timing parameters assume worst-case operating conditions (supply voltage and junction temperature). Values apply to all XC4000XL devices and are expressed in nanoseconds unless otherwise noted.

XC4000XL Global Early BUFGE #s 1, 2, 5, and 6 to IOB Clock

Description	Symbol	Speed Grade Device	All	-3	-2	-1	-09	-08	Units
			Min	Max	Max	Max	Max	Max	
Delay from pad through GE buffer to any IOB clock input.	T _{GE}	XC4002XL	0.1	1.6	1.4	1.3	1.2		ns
		XC4005XL	0.3	1.9	1.8	1.7	1.6		ns
		XC4010XL	0.3	2.2	1.9	1.7	1.7		ns
		XC4013XL	0.4	2.4	2.1	1.8	1.7	1.5	ns
		XC4020XL	0.4	2.6	2.2	2.1	2.0		ns
		XC4028XL	0.3	2.8	2.4	2.1	2.0		ns
		XC4036XL	0.3	3.1	2.7	2.3	2.2	1.9	ns
		XC4044XL	0.2	3.5	3.0	2.6	2.4		ns
		XC4052XL	0.3	4.0	3.5	3.0	3.0		ns
		XC4062XL	0.3	4.9	4.3	3.7	3.4	3.0	ns
XC4085XL	0.4	5.8	5.1	4.7	4.3		ns		

XC4000XL Global Early BUFGE #s 3, 4, 7, and 8 to IOB Clock

Description	Symbol	Speed Grade Device	All	-3	-2	-1	-09	-08	Units
			Min	Max	Max	Max	Max	Max	
Delay from pad through GE buffer to any IOB clock input.	T _{GE}	XC4002XL	0.5	2.8	2.5	2.1	1.7		ns
		XC4005XL	0.7	3.1	2.8	2.7	2.5		ns
		XC4010XL	0.7	3.5	3.1	2.8	2.7		ns
		XC4013XL	0.7	3.8	3.3	2.9	2.8	2.4	ns
		XC4020XL	0.8	4.1	3.6	3.4	3.2		ns
		XC4028XL	0.9	4.4	3.9	3.4	3.3		ns
		XC4036XL	0.9	4.7	4.2	3.7	3.6	3.1	ns
		XC4044XL	1.0	5.1	4.5	4.0	3.7		ns
		XC4052XL	1.1	5.5	4.8	4.3	4.3		ns
		XC4062XL	1.2	5.9	5.2	4.8	4.5	4.0	ns
XC4085XL	1.3	6.8	6.0	5.5	5.2		ns		

XC4000XL CLB Switching Characteristic Guidelines

Testing of switching parameters is modeled after testing methods specified by MIL-M-38510/605. All devices are 100% functionally tested. Internal timing parameters are derived from measuring internal test patterns. Listed below are representative values. For more specific, more precise, and worst-case guaranteed data, use the values reported by the static timing analyzer (TRCE in the Xilinx Development System) and back-annotated to the simulation netlist. All timing parameters assume worst-case operating conditions (supply voltage and junction temperature). Values apply to all XC4000XL devices and are expressed in nanoseconds unless otherwise noted.

Description	Speed Grade	-3		-2		-1		-09		-08	
	Symbol	Min	Max	Min	Max	Min	Max	Min	Max	Min	Max
Combinatorial Delays											
F/G inputs to X/Y outputs	T _{ILO}		1.6		1.5		1.3		1.2		1.1
F/G inputs via H' to X/Y outputs	T _{IHO}		2.7		2.4		2.2		2.0		1.9
F/G inputs via transparent latch to Q outputs	T _{ITO}		2.9		2.6		2.2		2.0		1.8
C inputs via SR/H0 via H to X/Y outputs	T _{HH0O}		2.5		2.2		2.0		1.8		1.8
C inputs via H1 via H to X/Y outputs	T _{HH1O}		2.4		2.1		1.9		1.6		1.5
C inputs via DIN/H2 via H to X/Y outputs	T _{HH2O}		2.5		2.2		2.0		1.8		1.8
C inputs via EC, DIN/H2 to YQ, XQ output (bypass)	T _{CBYP}		1.5		1.3		1.1		1.0		0.9
CLB Fast Carry Logic											
Operand inputs (F1, F2, G1, G4) to C _{OUT}	T _{OPCY}		2.7		2.3		2.0		1.6		1.6
Add/Subtract input (F3) to C _{OUT}	T _{ASCY}		3.3		2.9		2.5		1.8		1.8
Initialization inputs (F1, F3) to C _{OUT}	T _{INCY}		2.0		1.8		1.5		1.0		0.9
C _{IN} through function generators to X/Y outputs	T _{SUM}		2.8		2.6		2.4		1.7		1.5
C _{IN} to C _{OUT} , bypass function generators	T _{BYP}		0.26		0.23		0.20		0.14		0.14
Carry Net Delay, C _{OUT} to C _{IN}	T _{NET}		0.32		0.28		0.25		0.24		0.24
Sequential Delays											
Clock K to Flip-Flop outputs Q	T _{CKO}		2.1		1.9		1.6		1.5		1.4
Clock K to Latch outputs Q	T _{CKLO}		2.1		1.9		1.6		1.5		1.4
Setup Time before Clock K											
F/G inputs	T _{ICK}	1.1		1.0		0.9		0.8		0.8	
F/G inputs via H	T _{IHCK}	2.2		1.9		1.7		1.6		1.5	
C inputs via H0 through H	T _{HH0CK}	2.0		1.7		1.6		1.4		1.4	
C inputs via H1 through H	T _{HH1CK}	1.9		1.6		1.4		1.2		1.1	
C inputs via H2 through H	T _{HH2CK}	2.0		1.7		1.6		1.4		1.4	
C inputs via DIN	T _{DICK}	0.9		0.8		0.7		0.6		0.6	
C inputs via EC	T _{ECCK}	1.0		0.9		0.8		0.7		0.7	
C inputs via S/R, going Low (inactive)	T _{RCK}	0.6		0.5		0.5		0.4		0.4	
C _{IN} input via F/G	T _{CCK}	2.3		2.1		1.9		1.3		1.2	
C _{IN} input via F/G and H	T _{CHCK}	3.4		3.0		2.7		2.1		2.0	
Hold Time after Clock K											
F/G inputs	T _{CKI}	0		0		0		0		0	
F/G inputs via H	T _{CKIH}	0		0		0		0		0	
C inputs via SR/H0 through H	T _{CKHH0}	0		0		0		0		0	
C inputs via H1 through H	T _{CKHH1}	0		0		0		0		0	
C inputs via DIN/H2 through H	T _{CKHH2}	0		0		0		0		0	
C inputs via DIN/H2	T _{CKDI}	0		0		0		0		0	
C inputs via EC	T _{CKEC}	0		0		0		0		0	
C inputs via SR, going Low (inactive)	T _{CKR}	0		0		0		0		0	
Clock											
Clock High time	T _{CH}	3.0		2.8		2.5		2.3		2.1	
Clock Low time	T _{CL}	3.0		2.8		2.5		2.3		2.1	
Set/Reset Direct											
Width (High)	T _{RPW}	3.0		2.8		2.5		2.3		2.3	
Delay from C inputs via S/R, going High to Q	T _{RIO}		3.7		3.2		2.8		2.7		2.6
Global Set/Reset											
Minimum GSR Pulse Width	T _{MRW}		19.8		17.3		15.0		14.0		14.0
Delay from GSR input to any Q	T _{MRQ}	See page 14 for T _{RR1} values per device.									
Toggle Frequency (MHz) (for export control)	F _{TOG} (MHz)		166		179		200		217		238

XC4000XL RAM Synchronous (Edge-Triggered) Write Operation Guidelines

Testing of switching parameters is modeled after testing methods specified by MIL-M-38510/605. All devices are 100% functionally tested. Internal timing parameters are derived from measuring internal test patterns. Listed below are representative values. For more specific, more precise, and worst-case guaranteed data, use the values reported by the static timing analyzer (TRCE in the Xilinx Development System) and back-annotated to the simulation netlist. All timing parameters assume worst-case operating conditions (supply voltage and junction temperature). Values apply to all XC4000XL devices and are expressed in nanoseconds unless otherwise noted.

Single Port RAM	Speed Grade		-3		-2		-1		-09		-08	
	Size	Symbol	Min	Max	Min	Max	Min	Max	Min	Max	Min	Max
Write Operation												
Address write cycle time (clock K period)	16x2	T_{WCS}	9.0		8.4		7.7		7.4		7.4	
	32x1	T_{WCTS}	9.0		8.4		7.7		7.4		7.4	
Clock K pulse width (active edge)	16x2	T_{WPS}	4.5		4.2		3.9		3.7		3.7	
	32x1	T_{WPTS}	4.5		4.2		3.9		3.7		3.7	
Address setup time before clock K	16x2	T_{ASS}	2.2		2.0		1.7		1.7		1.6	
	32x1	T_{ASTS}	2.2		2.0		1.7		1.7		1.7	
Address hold time after clock K	16x2	T_{AHS}	0		0		0		0		0	
	32x1	T_{AHTS}	0		0		0		0		0	
DIN setup time before clock K	16x2	T_{DSS}	2.0		1.9		1.7		1.7		1.7	
	32x1	T_{DSTS}	2.5		2.3		2.1		2.1		2.1	
DIN hold time after clock K	16x2	T_{DHS}	0		0		0		0		0	
	32x1	T_{DHTS}	0		0		0		0		0	
WE setup time before clock K	16x2	T_{WSS}	2.0		1.8		1.6		1.6		1.6	
	32x1	T_{WSTS}	1.8		1.7		1.5		1.5		1.5	
WE hold time after clock K	16x2	T_{WHS}	0		0		0		0		0	
	32x1	T_{WHTS}	0		0		0		0		0	
Data valid after clock K	16x2	T_{WOS}		6.8		6.3		5.8		5.8		5.7
	32x1	T_{WOTS}		8.1		7.5		6.9		6.7		6.7
Read Operation												
Address read cycle time	16x2	T_{RC}	4.5		3.1		2.6		2.6		2.6	
	32x1	T_{RCT}	6.5		5.5		3.8		3.8		3.8	
Data Valid after address change (no Write Enable)	16x2	T_{ILO}		1.6		1.5		1.3		1.2		1.1
	32x1	T_{IHO}		2.7		2.4		2.2		2.0		1.9
Address setup time before clock K	16x2	T_{ICK}	1.1		1.0		0.9		0.8		0.8	
	32x1	T_{IHCK}	2.2		1.9		1.7		1.6		1.5	

XC4000XL CLB RAM Synchronous (Edge-Triggered) Write Operation Guidelines

Testing of switching parameters is modeled after testing methods specified by MIL-M-38510/605. All devices are 100% functionally tested. Internal timing parameters are derived from measuring internal test patterns. Listed below are representative values. For more specific, more precise, and worst-case guaranteed data, use the values reported by the static timing analyzer (TRCE in the Xilinx Development System) and back-annotated to the simulation netlist. All timing parameters assume worst-case operating conditions (supply voltage and junction temperature). Values apply to all XC4000XL devices and are expressed in nanoseconds unless otherwise noted.

Dual Port RAM	Speed Grade		-3		-2		-1		-09		-08	
	Size	Symbol	Min	Max	Min	Max	Min	Max	Min	Max	Min	Max
Address write cycle time (clock K period)	16x1	T_{WCDS}	9.0		8.4		7.7		7.4		7.4	
Clock K pulse width (active edge)	16x1	T_{WPDS}	4.5		4.2		3.9		3.7		3.7	
Address setup time before clock K	16x1	T_{ASDS}	2.5		2.0		1.7		1.7		1.6	
Address hold time after clock K	16x1	T_{AHDS}	0		0		0		0		0	
DIN setup time before clock K	16x1	T_{DSDS}	2.5		2.3		2.0		2.0		2.0	
DIN hold time after clock K	16x1	T_{DHDS}	0		0		0		0		0	
WE setup time before clock K	16x1	T_{WSDS}	1.8		1.7		1.6		1.6		1.6	
WE hold time after clock K	16x1	T_{WHDS}	0		0		0		0		0	
Data valid after clock K	16x1	T_{WODS}		7.8		7.3		6.7		6.7		6.6

XC4000XL CLB RAM Synchronous (Edge-Triggered) Write Timing

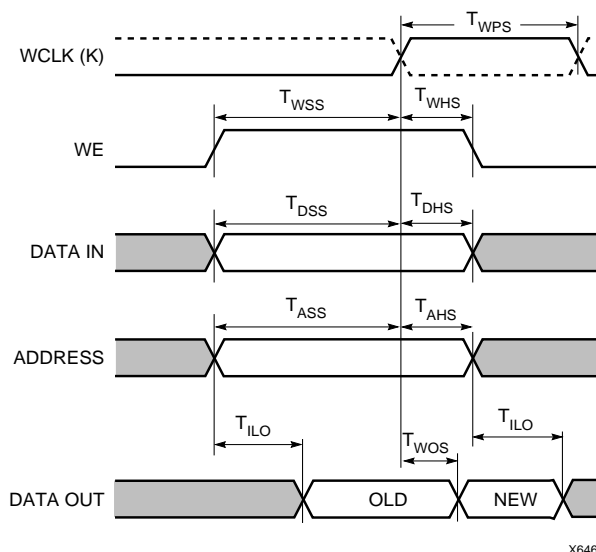
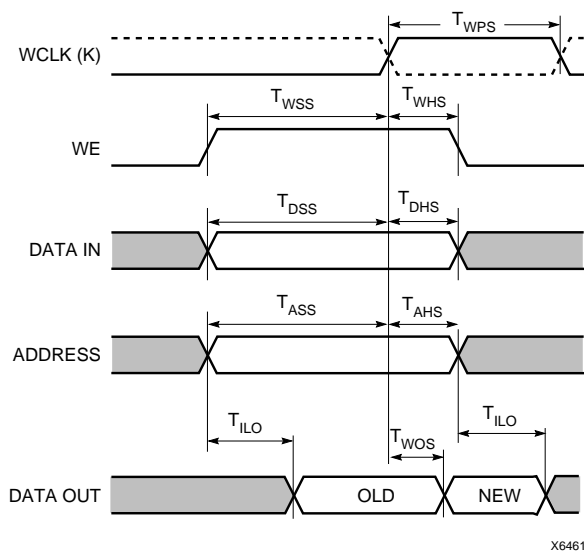

XC4000XL Pin-to-Pin Output Parameter Guidelines

Testing of switching parameters is modeled after testing methods specified by MIL-M-38510/605. All devices are 100% functionally tested. Pin-to-pin timing parameters are derived from measuring external and internal test patterns and are guaranteed over worst-case operating conditions (supply voltage and junction temperature). Listed below are representative values for typical pin locations and normal clock loading. For more specific, more precise, and worst-case guaranteed data, reflecting the actual routing structure, use the values provided by the static timing analyzer (TRCE in the Xilinx Development System) and back-annotated to the simulation netlist. These path delays, provided as a guideline, have been extracted from the static timing analyzer report. Values are expressed in nanoseconds unless otherwise noted.

XC4000XL Output Flip-Flop, Clock to Out

Description	Symbol	Device	Speed Grade						Units
			All	-3	-2	-1	-09	-08	
			Min	Max	Max	Max	Max	Max	
Global Low Skew Clock to Output using Output Flip Flop	T _{ICKOF}	XC4002XL	1.2	7.1	6.1	5.4	5.1		ns
		XC4005XL	1.3	7.7	6.6	5.8	5.4		ns
		XC4010XL	1.4	8.2	7.1	6.2	5.8		ns
		XC4013XL	1.5	8.6	7.4	6.5	6.1	5.6	ns
		XC4020XL	1.6	9.0	7.8	6.8	6.4		ns
		XC4028XL	1.8	9.4	8.1	7.1	6.7		ns
		XC4036XL	2.0	9.8	8.5	7.4	7.0	6.4	ns
		XC4044XL	2.1	10.3	8.9	7.8	7.4		ns
		XC4052XL	2.2	10.7	9.3	8.3	7.9		ns
		XC4062XL	2.3	11.3	9.7	8.5	8.1	7.3	ns
		XC4085XL	2.5	12.2	10.5	9.5	9.0		ns
For output SLOW option add	T _{SLOW}	All Devices	0.5	3.0	2.5	2.0	1.7	1.6	ns

Notes: Clock-to-out minimum delay is measured with the fastest route and the lightest load, Clock-to-out maximum delay is measured using the farthest distance and a reference load of one clock pin (IK or OK) per IOB as well as driving all accessible CLB flip-flops. For designs with a smaller number of clock loads, the pad-to-IOB clock pin delay as determined by the static timing analyzer (TRCE) can be added to the AC parameter Tokpof and used as a worst-case pin-to-pin clock-to-out delay for clocked outputs for FAST mode configurations.

Output timing is measured at ~50% V_{CC} threshold with 50 pF external capacitive load. For different loads, see Figure 1.

Capacitive Load Factor

Figure 1 shows the relationship between I/O output delay and load capacitance. It allows a user to adjust the specified output delay if the load capacitance is different than 50 pF. For example, if the actual load capacitance is 120 pF, add 2.5 ns to the specified delay. If the load capacitance is 20 pF, subtract 0.8 ns from the specified output delay.

Figure 1 is usable over the specified operating conditions of voltage and temperature and is independent of the output slew rate control.

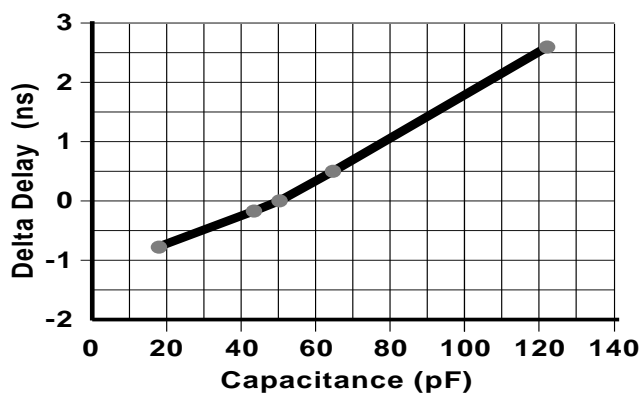

Figure 1: Delay Factor at Various Capacitive Loads

XC4000XL Pin-to-Pin Output Parameter Guidelines

Testing of switching parameters is modeled after testing methods specified by MIL-M-38510/605. All devices are 100% functionally tested. Pin-to-pin timing parameters are derived from measuring external and internal test patterns and are guaranteed over worst-case operating conditions (supply voltage and junction temperature). Listed below are representative values for typical pin locations and normal clock loading. For more specific, more precise, and worst-case guaranteed data, reflecting the actual routing structure, use the values provided by the static timing analyzer (TRCE in the Xilinx Development System) and back-annotated to the simulation netlist. These path delays, provided as a guideline, have been extracted from the static timing analyzer report. Values are expressed in nanoseconds unless otherwise noted.

XC4000XL Output Flip-Flop, Clock to Out, BUFGE #s 1, 2, 5, and 6

Description	Symbol	Device	Speed Grade					Units	
			All	-3	-2	-1	-09		-08
			Min	Max	Max	Max	Max	Max	
Global Early Clock to Output using Output Flip Flop. Values are for BUFGE #s 1, 2, 5, and 6.	T _{ICKEOF}	XC4002XL	1.0	6.6	5.7	5.1	4.8		ns
		XC4005XL	1.2	6.9	6.1	5.5	5.2		ns
		XC4010XL	1.2	7.2	6.2	5.5	5.3		ns
		XC4013XL	1.3	7.4	6.4	5.6	5.3	4.8	ns
		XC4020XL	1.3	7.6	6.5	5.9	5.6		ns
		XC4028XL	1.2	7.8	6.7	5.9	5.6		ns
		XC4036XL	1.2	8.1	7.0	6.1	5.8	5.2	ns
		XC4044XL	1.1	8.5	7.3	6.4	6.0		ns
		XC4052XL	1.2	9.0	7.8	6.8	6.6		ns
		XC4062XL	1.2	9.9	8.6	7.5	7.0	6.3	ns
XC4085XL	1.3	10.8	9.4	8.5	7.9		ns		

Notes: Clock-to-out minimum delay is measured with the fastest route and the lightest load, Clock-to-out maximum delay is measured using the farthest distance and a reference load of one clock pin (IK or OK) per IOB as well as driving all accessible CLB flip-flops. For designs with a smaller number of clock loads, the pad-to-IOB clock pin delay as determined by the static timing analyzer (TRCE) can be added to the AC parameter Tokpof and used as a worst-case pin-to-pin clock-to-out delay for clocked outputs for FAST mode configurations.

Output timing is measured at ~50% V_{CC} threshold with 50 pF external capacitive load. For different loads, see Figure 1.

XC4000XL Output Flip-Flop, Clock to Out, BUFGE #s 3, 4, 7, and 8

Description	Symbol	Device	Speed Grade					Units	
			All	-3	-2	-1	-09		-08
			Min	Max	Max	Max	Max	Max	
Global Early Clock to Output using Output Flip Flop. Values are for BUFGE #s 3, 4, 7, and 8.	T _{ICKEOF}	XC4002XL	1.3	7.8	6.8	5.9	5.3		ns
		XC4005XL	1.5	8.1	7.1	6.5	6.1		ns
		XC4010XL	1.6	8.5	7.4	6.6	6.3		ns
		XC4013XL	1.6	8.8	7.6	6.7	6.4	5.7	ns
		XC4020XL	1.7	9.1	7.9	7.2	6.8		ns
		XC4028XL	1.7	9.4	8.2	7.2	6.9		ns
		XC4036XL	1.8	9.7	8.5	7.5	7.2	6.4	ns
		XC4044XL	1.9	10.1	8.8	7.8	7.3		ns
		XC4052XL	2.0	10.5	9.1	8.1	7.9		ns
		XC4062XL	2.0	10.9	9.5	8.6	8.1	7.3	ns
XC4085XL	2.2	11.8	10.3	9.3	8.8		ns		

Notes: Clock-to-out minimum delay is measured with the fastest route and the lightest load, Clock-to-out maximum delay is measured using the farthest distance and a reference load of one clock pin (IK or OK) per IOB as well as driving all accessible CLB flip-flops. For designs with a smaller number of clock loads, the pad-to-IOB clock pin delay as determined by the static timing analyzer (TRCE) can be added to the AC parameter Tokpof and used as a worst-case pin-to-pin clock-to-out delay for clocked outputs for FAST mode configurations.

Output timing is measured at ~50% V_{CC} threshold with 50 pF external capacitive load. For different loads, see Figure 1.

XC4000XL Pin-to-Pin Input Parameter Guidelines

Testing of switching parameters is modeled after testing methods specified by MIL-M-38510/605. All devices are 100% functionally tested. Pin-to-pin timing parameters are derived from measuring external and internal test patterns and are guaranteed over worst-case operating conditions (supply voltage and junction temperature). Listed below are representative values for typical pin locations and normal clock loading. For more specific, more precise, and worst-case guaranteed data, reflecting the actual routing structure, use the values provided by the static timing analyzer (TRCE in the Xilinx Development System) and back-annotated to the simulation netlist. These path delays, provided as a guideline, have been extracted from the static timing analyzer report. Values are expressed in nanoseconds unless otherwise noted

XC4000XL Global Low Skew Clock, Set-Up and Hold

Description	Symbol	Device	Speed Grade					Units
			-3 Min	-2 Min	-1 Min	-09 Min	-08 Min	
Input Setup and Hold Times								
No Delay Global Low Skew Clock and IFF Global Low Skew Clock and FCL	T_{PSN}/T_{PHN}	XC4002XL	2.5 / 1.5	2.2 / 1.3	1.9 / 1.2	1.7 / 1.0		ns
		XC4005XL	1.2 / 2.6	1.1 / 2.2	0.9 / 2.0	0.8 / 1.7		ns
		XC4010XL	1.2 / 3.0	1.1 / 2.6	0.9 / 2.3	0.8 / 2.0		ns
		XC4013XL	1.2 / 3.2	1.1 / 2.8	0.9 / 2.4	0.8 / 2.1	0.8 / 2.1	ns
		XC4020XL	1.2 / 3.7	1.1 / 3.2	0.9 / 2.8	0.8 / 2.4		ns
		XC4028XL	1.2 / 4.4	1.1 / 3.8	0.9 / 3.3	0.8 / 2.9		ns
		XC4036XL	1.2 / 5.5	1.1 / 4.8	0.9 / 4.1	0.8 / 3.6	0.8 / 3.6	ns
		XC4044XL	1.2 / 5.8	1.1 / 5.0	0.9 / 4.4	0.8 / 3.8		ns
		XC4052XL	1.2 / 7.1	1.1 / 6.2	0.9 / 5.4	0.8 / 4.7		ns
		XC4062XL	1.2 / 7.0	1.1 / 6.1	0.9 / 5.3	0.8 / 4.6	0.8 / 4.6	ns
XC4085XL	1.2 / 9.4	1.1 / 8.2	0.9 / 7.1	0.8 / 6.2		ns		
Partial Delay Global Low Skew Clock and IFF Global Low Skew Clock and FCL	T_{PSP}/T_{PHP}	XC4002XL	8.4 / 0.0	7.3 / 0.0	6.3 / 0.0	5.5 / 0.0		ns
		XC4005XL	10.5 / 0.0	9.1 / 0.0	7.9 / 0.0	6.9 / 0.0		ns
		XC4010XL	11.1 / 0.0	9.7 / 0.0	8.4 / 0.0	7.3 / 0.0		ns
		XC4013XL*	6.1 / 1.0	5.3 / 1.0	4.6 / 1.0	4.0 / 1.0	3.7 / 0.5	ns
		XC4020XL	11.9 / 1.0	10.3 / 1.0	9.0 / 1.0	7.8 / 1.0		ns
		XC4028XL	12.3 / 1.0	10.7 / 1.0	9.3 / 1.0	8.1 / 1.0		ns
		XC4036XL*	6.4 / 1.0	5.6 / 1.0	4.8 / 1.0	4.2 / 1.0	4.0 / 0.8	ns
		XC4044XL	13.1 / 1.0	11.4 / 1.0	9.9 / 1.0	8.6 / 1.0		ns
		XC4052XL	11.9 / 1.0	10.3 / 1.0	9.0 / 1.0	7.8 / 1.0		ns
		XC4062XL*	6.7 / 1.2	5.8 / 1.2	5.1 / 1.2	4.4 / 1.2	4.2 / 1.0	ns
XC4085XL	12.9 / 1.2	11.2 / 1.2	9.8 / 1.2	8.5 / 1.2		ns		
Full Delay Global Low Skew Clock and IFF	T_{PSD}/T_{PHD}	XC4002XL	6.8 / 0.0	6.0 / 0.0	5.2 / 0.0	4.5 / 0.0		ns
		XC4005XL	8.8 / 0.0	7.6 / 0.0	6.6 / 0.0	5.6 / 0.0		ns
		XC4010XL	9.0 / 0.0	7.8 / 0.0	6.8 / 0.0	5.8 / 0.0		ns
		XC4013XL*	6.4 / 0.0	6.0 / 0.0	5.6 / 0.0	4.8 / 0.0	4.8 / 0.0	ns
		XC4020XL	8.8 / 0.0	7.6 / 0.0	6.6 / 0.0	6.2 / 0.0		ns
		XC4028XL	9.3 / 0.0	8.1 / 0.0	7.0 / 0.0	6.4 / 0.0		ns
		XC4036XL*	6.6 / 0.0	6.2 / 0.0	5.8 / 0.0	5.3 / 0.0	5.3 / 0.0	ns
		XC4044XL	10.6 / 0.0	9.2 / 0.0	8.0 / 0.0	6.8 / 0.0		ns
		XC4052XL	11.2 / 0.0	9.7 / 0.0	8.4 / 0.0	7.0 / 0.0		ns
		XC4062XL*	6.8 / 0.0	6.4 / 0.0	6.0 / 0.0	5.5 / 0.0	5.5 / 0.0	ns
XC4085XL	12.7 / 0.0	11.0 / 0.0	9.6 / 0.0	8.4 / 0.0		ns		

IFF = Input Flip-Flop or Latch

Notes: Input setup time is measured with the fastest route and the lightest load.

Input hold time is measured using the furthest distance and a reference load of one clock pin per IOB as well as driving all accessible CLB flip-flops. For designs with a smaller number of clock loads, the pad-to-IOB clock pin delay as determined by the static timing analyzer (TRCE) can be used as a worst-case pin-to-pin no-delay input hold specification.

* The XC4013XL, XC4036XL, and 4062XL have significantly faster partial and full delay setup times than other devices.

XC4000XL BUFGE #s 1, 2, 5, and 6 Global Early Clock, Set-up and Hold for IFF and FCL

Testing of switching parameters is modeled after testing methods specified by MIL-M-38510/605. All devices are 100% functionally tested. Pin-to-pin timing parameters are derived from measuring external and internal test patterns and are guaranteed over worst-case operating conditions (supply voltage and junction temperature). Listed below are representative values for typical pin locations and normal clock loading. For more specific, more precise, and worst-case guaranteed data, reflecting the actual routing structure, use the values provided by the static timing analyzer (TRCE in the Xilinx Development System) and back-annotated to the simulation netlist. These path delays, provided as a guideline, have been extracted from the static timing analyzer report. Values are expressed in nanoseconds unless otherwise noted.

Description	Symbol	Device	Speed Grade					Units
			-3	-2	-1	-09	-08	
			Min	Min	Min	Min	Min	
Input Setup and Hold Times								
No Delay Global Early Clock and IFF Global Early Clock and FCL	T_{PSEN}/T_{PHEN} T_{PFSEN}/T_{PFHEN}	XC4002XL	2.8 / 1.5	2.5 / 1.3	2.2 / 1.2	1.9 / 1.0		ns
		XC4005XL	1.2 / 4.1	1.1 / 3.6	0.9 / 3.1	0.8 / 2.7		ns
		XC4010XL	1.2 / 4.4	1.1 / 3.8	0.9 / 3.3	0.8 / 2.9		ns
		XC4013XL	1.2 / 4.7	1.1 / 4.1	0.9 / 3.6	0.8 / 3.1	0.5 / 2.7	ns
		XC4020XL	1.2 / 4.6	1.1 / 4.0	0.9 / 3.5	0.8 / 3.0		ns
		XC4028XL	1.2 / 5.3	1.1 / 4.6	0.9 / 4.0	0.8 / 3.5		ns
		XC4036XL	1.2 / 6.7	1.1 / 5.8	0.9 / 5.1	0.8 / 4.4	0.5 / 3.7	ns
		XC4044XL	1.2 / 6.5	1.1 / 5.7	0.9 / 4.9	0.8 / 4.3		ns
		XC4052XL	1.2 / 6.7	1.1 / 5.8	0.9 / 5.1	0.8 / 4.4		ns
		XC4062XL	1.2 / 8.4	1.1 / 7.3	0.9 / 6.3	0.8 / 5.5	0.5 / 4.7	ns
		XC4085XL	1.2 / 8.7	1.1 / 7.5	0.9 / 6.6	0.8 / 5.7		ns
Partial Delay Global Early Clock and IFF Global Early Clock and FCL	T_{PSEP}/T_{PHEP} T_{PFSEP}/T_{PFHEP}	XC4002XL	8.1 / 0.9	7.0 / 0.8	6.1 / 0.7	5.3 / 0.6		ns
		XC4005XL	9.0 / 0.0	8.5 / 0.0	8.0 / 0.0	7.5 / 0.0		ns
		XC4010XL	11.9 / 0.0	10.4 / 0.0	9.0 / 0.0	8.0 / 0.0		ns
		XC4013XL*	6.4 / 0.0	5.9 / 0.0	5.4 / 0.0	4.9 / 0.0	4.4 / 0.0	ns
		XC4020XL	10.8 / 0.0	10.3 / 0.0	9.8 / 0.0	9.0 / 0.0		ns
		XC4028XL	14.0 / 0.0	12.2 / 0.0	10.6 / 0.0	9.8 / 0.0		ns
		XC4036XL*	7.0 / 0.0	6.6 / 0.0	6.2 / 0.0	5.2 / 0.0	4.7 / 0.0	ns
		XC4044XL	14.6 / 0.0	12.7 / 0.0	11.0 / 0.0	10.8 / 0.0		ns
		XC4052XL	16.4 / 0.0	14.3 / 0.0	12.4 / 0.0	11.4 / 0.0		ns
		XC4062XL*	9.0 / 0.8	8.6 / 0.8	8.2 / 0.8	7.0 / 0.8	6.3 / 0.5	ns
		XC4085XL	16.7 / 0.0	14.5 / 0.0	12.6 / 0.0	11.6 / 0.0		ns
Full Delay Global Early Clock and IFF	T_{PSED}/T_{PHED}	XC4002XL	6.7 / 0.0	5.8 / 0.0	5.1 / 0.0	4.4 / 0.0		ns
		XC4005XL	10.8 / 0.0	9.4 / 0.0	8.2 / 0.0	7.1 / 0.0		ns
		XC4010XL	10.3 / 0.0	9.0 / 0.0	7.8 / 0.0	6.8 / 0.0		ns
		XC4013XL*	10.0 / 0.0	8.7 / 0.0	7.6 / 0.0	6.6 / 0.0	6.0 / 0.0	ns
		XC4020XL	12.0 / 0.0	10.4 / 0.0	9.1 / 0.0	7.9 / 0.0		ns
		XC4028XL	12.6 / 0.0	11.0 / 0.0	9.5 / 0.0	8.3 / 0.0		ns
		XC4036XL*	12.2 / 0.0	10.6 / 0.0	9.2 / 0.0	8.0 / 0.0	7.2 / 0.0	ns
		XC4044XL	13.8 / 0.0	12.0 / 0.0	10.5 / 0.0	9.1 / 0.0		ns
		XC4052XL	14.1 / 0.0	12.3 / 0.0	10.7 / 0.0	9.3 / 0.0		ns
		XC4062XL*	13.1 / 0.0	11.4 / 0.0	9.9 / 0.0	8.6 / 0.0	7.8 / 0.0	ns
		XC4085XL	17.9 / 0.0	15.6 / 0.0	13.6 / 0.0	11.8 / 0.0		ns

IFF = Input Flip-Flop or Latch, FCL = Fast Capture Latch

Notes: Input setup time is measured with the fastest route and the lightest load.

Input hold time is measured using the furthest distance and a reference load of one clock pin per IOB as well as driving all accessible CLB flip-flops. For designs with a smaller number of clock loads, the pad-to-IOB clock pin delay as determined by the static timing analyzer (TRCE) can be used as a worst-case pin-to-pin no-delay input hold specification.

* The XC4013XL, XC4036XL, and 4062XL have significantly faster partial and full delay setup times than other devices.

XC4000XL BUFGE #s 3, 4, 7, and 8 Global Early Clock, Set-up and Hold for IFF and FCL

Testing of switching parameters is modeled after testing methods specified by MIL-M-38510/605. All devices are 100% functionally tested. Pin-to-pin timing parameters are derived from measuring external and internal test patterns and are guaranteed over worst-case operating conditions (supply voltage and junction temperature). Listed below are representative values for typical pin locations and normal clock loading. For more specific, more precise, and worst-case guaranteed data, reflecting the actual routing structure, use the values provided by the static timing analyzer (TRCE in the Xilinx Development System) and back-annotated to the simulation netlist. These path delays, provided as a guideline, have been extracted from the static timing analyzer report. Values are expressed in nanoseconds unless otherwise noted.

Description	Symbol	Speed Grade	-3	-2	-1	-09	-08	Units
		Device	Min	Min	Min	Min	Min	
Input Setup & Hold Times								
No Delay Global Early Clock and IFF Global Early Clock and FCL	T_{PSEN}/T_{PHEN} T_{PFSEN}/T_{PFHEN}	XC4002XL	3.0 / 2.0	2.6 / 1.7	2.3 / 1.5	2.0 / 1.3		ns
		XC4005XL	1.2 / 4.1	1.1 / 3.6	0.9 / 3.1	0.8 / 2.7		ns
		XC4010XL	1.2 / 4.4	1.1 / 3.8	0.9 / 3.3	0.8 / 2.9		ns
		XC4013XL	1.2 / 4.7	1.1 / 4.1	0.9 / 3.6	0.8 / 3.1	0.5 / 2.7	ns
		XC4020XL	1.2 / 4.6	1.1 / 4.0	0.9 / 3.5	0.8 / 3.0		ns
		XC4028XL	1.2 / 5.3	1.1 / 4.6	0.9 / 4.0	0.8 / 3.5		ns
		XC4036XL	1.2 / 6.7	1.1 / 5.8	0.9 / 5.1	0.8 / 4.4	0.5 / 3.7	ns
		XC4044XL	1.2 / 6.5	1.1 / 5.7	0.9 / 4.9	0.8 / 4.3		ns
		XC4052XL	1.2 / 6.7	1.1 / 5.8	0.9 / 5.1	0.8 / 4.4		ns
		XC4062XL	1.2 / 8.4	1.1 / 7.3	0.9 / 6.3	0.8 / 5.5	0.5 / 4.7	ns
XC4085XL	1.2 / 8.7	1.1 / 7.5	0.9 / 6.6	0.8 / 5.7		ns		
Partial Delay Global Early Clock and IFF Global Early Clock and FCL	T_{PSEP}/T_{PHEP} T_{PFSEP}/T_{PFHEP}	XC4002XL	7.3 / 1.5	6.4 / 1.3	5.5 / 1.2	4.8 / 1.0		ns
		XC4005XL	8.4 / 0.0	7.9 / 0.0	7.4 / 0.0	7.2 / 0.0		ns
		XC4010XL	10.3 / 0.0	9.0 / 0.0	7.8 / 0.0	7.4 / 0.0		ns
		XC4013XL*	5.4 / 0.0	4.9 / 0.0	4.4 / 0.0	4.3 / 0.0	4.0 / 0.0	ns
		XC4020XL	9.8 / 0.0	9.3 / 0.0	8.8 / 0.0	8.5 / 0.0		ns
		XC4028XL	12.7 / 0.0	11.0 / 0.0	9.6 / 0.0	9.3 / 0.0		ns
		XC4036XL*	6.4 / 0.8	5.9 / 0.8	5.4 / 0.8	5.0 / 0.8	4.6 / 0.2	ns
		XC4044XL	13.8 / 0.0	12.0 / 0.0	10.4 / 0.0	10.2 / 0.0		ns
		XC4052XL	14.5 / 0.0	12.7 / 0.0	11.0 / 0.0	10.7 / 0.0		ns
		XC4062XL*	8.4 / 1.5	7.9 / 1.5	7.4 / 1.5	6.8 / 1.5	6.2 / 0.0	ns
XC4085XL	14.5 / 0.0	12.7 / 0.0	11.0 / 0.0	10.8 / 0.0		ns		
Full Delay Global Early Clock and IFF	T_{PSED}/T_{PHED}	XC4002XL	5.9 / 0.0	5.2 / 0.0	4.5 / 0.0	3.9 / 0.0		ns
		XC4005XL	10.8 / 0.0	9.4 / 0.0	8.2 / 0.0	7.1 / 0.0		ns
		XC4010XL	10.3 / 0.0	9.0 / 0.0	7.8 / 0.0	6.8 / 0.0		ns
		XC4013XL*	10.0 / 0.0	8.7 / 0.0	7.6 / 0.0	6.6 / 0.0	6.0 / 0.0	ns
		XC4020XL	12.0 / 0.0	10.4 / 0.0	9.1 / 0.0	7.9 / 0.0		ns
		XC4028XL	12.6 / 0.0	11.0 / 0.0	9.5 / 0.0	8.3 / 0.0		ns
		XC4036XL*	12.2 / 0.0	10.6 / 0.0	9.2 / 0.0	8.0 / 0.0	7.2 / 0.0	ns
		XC4044XL	13.8 / 0.0	12.0 / 0.0	10.5 / 0.0	9.1 / 0.0		ns
		XC4052XL	14.1 / 0.0	12.3 / 0.0	10.7 / 0.0	9.3 / 0.0		ns
		XC4062XL*	13.1 / 0.0	11.4 / 0.0	9.9 / 0.0	8.6 / 0.0	7.8 / 0.0	ns
XC4085XL	17.9 / 0.0	15.6 / 0.0	13.6 / 0.0	11.8 / 0.0		ns		

IFF = Input Flip Flop or Latch. FCL = Fast Capture Latch

Notes: Input setup time is measured with the fastest route and the lightest load.

Input hold time is measured using the furthest distance and a reference load of one clock pin per IOB as well as driving all accessible CLB flip-flops. For designs with a smaller number of clock loads, the pad-to-IOB clock pin delay as determined by the static timing analyzer (TRCE) can be used as a worst-case pin-to-pin no-delay input hold specification.

* The XC4013XL, XC4036XL, and 4062XL have significantly faster partial and full delay setup times than other devices.

XC4000XL IOB Input Switching Characteristic Guidelines

Testing of switching parameters is modeled after testing methods specified by MIL-M-38510/605. All devices are 100% functionally tested. Internal timing parameters are derived from measuring internal test patterns. Listed below are representative values. For more specific, more precise, and worst-case guaranteed data, use the values reported by the static timing analyzer (TRCE in the Xilinx Development System) and back-annotated to the simulation netlist. These path delays, provided as a guideline, have been extracted from the static timing analyzer report. All timing parameters assume worst-case operating conditions (supply voltage and junction temperature).

Description	Symbol	Speed Grade Device	-3	-2	-1	-09	-08	Units
			Min	Min	Min	Min	Min	
Clocks								
Clock Enable (EC) to Clock (IK)	T _{ECIK}	All devices	0.1	0.1	0.1	0.1	0.1	ns
Delay from FCL enable (OK) active edge to IFF clock (IK) active edge	T _{OKIK}	XC4002XL	3.0	2.7	2.3	2.3		ns
		XC4013, 36, 62XL	2.2	1.9	1.6	1.6	1.6	ns
		Balance of Family	2.2	1.9	1.6	1.6		ns
Setup Times								
Pad to Clock (IK), no delay	T _{PICK}	XC4002XL	2.6	2.3	2.0	2.0		ns
		XC4013, 36, 62XL	1.7	1.5	1.3	1.3	1.2	ns
		Balance of Family	1.7	1.5	1.3	1.3		ns
Pad to Clock (IK), via transparent Fast Capture Latch, no delay	T _{PICKF}	XC4002XL	3.2	2.9	2.5	2.4		ns
		XC4013, 36, 62XL	2.3	2.0	1.8	1.7	1.6	ns
		Balance of Family	2.3	2.0	1.8	1.7		ns
Pad to Fast Capture Latch Enable (OK), no delay	T _{POCK}	XC4013, 36, 62XL	1.2	1.0	0.9	0.9	0.9	ns
		Balance of Family	1.2	1.0	0.9	0.9		ns
Hold Times								
All Hold Times		All Devices	0	0	0	0	0	
Global Set/Reset								
Minimum GSR Pulse Width	T _{MRW}	All devices	19.8	17.3	15.0	14.0	14.0	ns
Global Set/Reset			Max	Max	Max	Max	Max	
Delay from GSR input to any Q	T _{RRI} *	XC4002XL	9.8	8.5	7.4	7.0		ns
		XC4005XL	11.3	9.8	8.5	8.1		ns
		XC4010XL	13.9	12.1	10.5	10.0		ns
		XC4013XL	15.9	13.8	12.0	11.4	10.9	ns
		XC4020XL	18.6	16.1	14.0	13.3		ns
		XC4028XL	20.5	17.9	15.5	14.3		ns
		XC4036XL	22.5	19.6	17.0	16.2	16.2	ns
		XC4044XL	25.1	21.9	19.0	18.1		ns
		XC4052XL	27.2	23.6	20.5	19.5		ns
		XC4062XL	29.1	25.3	22.0	20.9	20.4	ns
XC4085XL	34.4	29.9	26.0	24.7		ns		

* Indicates Minimum Amount of Time to Assure Valid Data. IFF = Input Flip-Flop or Latch, FCL = Fast Capture Latch.

XC4000XL IOB Input Switching Characteristic Guidelines (Cont)

Testing of switching parameters is modeled after testing methods specified by MIL-M-38510/605. All devices are 100% functionally tested. Internal timing parameters are derived from measuring internal test patterns. Listed below are representative values. For more specific, more precise, and worst-case guaranteed data, use the values reported by the static timing analyzer (TRCE in the Xilinx Development System) and back-annotated to the simulation netlist. These path delays, provided as a guideline, have been extracted from the static timing analyzer report. All timing parameters assume worst-case operating conditions (supply voltage and junction temperature).

Description	Symbol	Speed Grade Device	-3	-2	-1	-09	-08	Units
			Max	Max	Max	Max	Max	
Propagation Delays								
Pad to I1, I2	T_{PID}	All devices	1.6	1.4	1.2	1.1	1.0	ns
Pad to I1, I2 via transparent input latch, no delay	T_{PLI}	XC4002XL	4.7	4.2	3.6	3.5		ns
		XC4013, 36, 62XL	3.1	2.7	2.4	2.2	2.1	ns
		Balance of Family	3.1	2.7	2.4	2.2		ns
Pad to I1, I2 via transparent FCL and in- put latch, no delay	T_{PFLI}	X4002XL	5.4	4.7	4.1	3.9		ns
		XC4013, 36, 62XL	3.7	3.3	2.8	2.7	2.5	ns
		Balance of Family	3.7	3.3	2.8	2.7		ns
Clock (IK) to I1, I2 (flip-flop)	T_{IKRI}	All devices	1.7	1.5	1.3	1.2	1.2	ns
Clock (IK) to I1, I2 (latch enable, active Low)	T_{IKLI}	All devices	1.8	1.6	1.4	1.3	1.3	ns
FCL Enable (OK) active edge to I1, I2 (via transparent standard input latch)	T_{OKLI}	XC4002XL	5.2	4.6	4.0	3.8		ns
		XC4013, 36, 62XL	3.6	3.1	2.7	2.6	2.5	ns
		Balance of Family	3.6	3.1	2.7	2.6		ns

IFF = Input Flip-Flop or Latch, FCL = Fast Capture Latch

XC4000XL IOB Output Switching Characteristic Guidelines

Testing of switching parameters is modeled after testing methods specified by MIL-M-38510/605. All devices are 100% functionally tested. Internal timing parameters are derived from measuring internal test patterns. Listed below are representative values. For more specific, more precise, and worst-case guaranteed data, use the values reported by the static timing analyzer (TRCE in the Xilinx Development System) and back-annotated to the simulation netlist. These path delays, provided as a guideline, have been extracted from the static timing analyzer report. All timing parameters assume worst-case operating conditions (supply voltage and junction temperature). For Propagation Delays, slew-rate = fast unless otherwise noted. Values are expressed in nanoseconds unless otherwise noted.

		-3		-2		-1		-09		-08	
Description	Symbol	Min	Max	Min	Max	Min	Max	Min	Max	Min	Max
Clocks											
Clock High	T _{CH}	3.0		2.8		2.5		2.3		2.1	
Clock Low	T _{CL}	3.0		2.8		2.5		2.3		2.1	
Propagation Delays											
Clock (OK) to Pad	T _{OKPOF}		5.0		4.3		3.8		3.5		3.3
Output (O) to Pad	T _{OPF}		4.1		3.6		3.1		3.0		2.8
3-state to Pad hi-Z (slew-rate independent)	T _{TSHZ}		4.0		3.5		3.0		2.9		2.9
3-state to Pad active and valid	T _{TSONF}		4.4		3.8		3.3		3.3		3.3
Output (O) to Pad via Fast Output MUX	T _{OFFPF}		5.5		4.8		4.2		4.0		3.7
Select (OK) to Pad via Fast MUX	T _{OKFPF}		5.1		4.5		3.9		3.7		3.4
Setup and Hold Times											
Output (O) to clock (OK) setup time	T _{OOK}	0.5		0.4		0.3		0.3		0.3	
Output (O) to clock (OK) hold time	T _{OKO}	0.0		0.0		0.0		0.0		0.0	
Clock Enable (EC) to clock (OK) setup time	T _{ECOK}	0.0		0.0		0.0		0.0		0.0	
Clock Enable (EC) to clock (OK) hold time	T _{OKEC}	0.3		0.2		0.1		0.0		0.0	
Global Set/Reset											
Minimum GSR pulse width	T _{MRW}	19.8		17.3		15.0		14.0		14.0	
Delay from GSR input to any Pad	T _{RPO*}										
XC4002XL			14.3		12.5		10.9		10.3		
XC4005XL			15.9		13.8		12.0		11.4		
XC4010XL			18.5		16.1		14.0		13.3		14.0
XC4013XL			20.5		17.8		15.5		14.7		
XC4020XL			23.2		20.1		17.5		16.6		
XC4028XL			25.1		21.9		19.0		17.6		
XC4036XL			27.1		23.6		20.5		19.4		19.3
XC4044XL			29.7		25.9		22.5		21.4		
XC4052XL			31.7		27.6		24.0		22.8		
XC4062XL			33.7		29.3		25.5		24.2		23.5
XC4085XL			39.0		33.9		29.5		28.0		
Slew Rate Adjustment											
For output SLOW option add	T _{SLOW}		3.0		2.5		2.0		1.7		1.6

Note: Output timing is measured at ~50% V_{CC} threshold, with 50 pF external capacitive loads.

* Indicates Minimum Amount of Time to Assure Valid Data.

Revision Record

Revision Source ADSXC4000XL002, September 24, 1998, (Version 0.02)

Internal Reference: PDSXC4000XL0021, December 9, 1998 (Version 0.02.1),

ADSXC4000XL003w, December 9, 1998 (Version 0.03) and

4000XL003wr, December 9, 1998 (Version 2.1)