

Debugging, for example, would be a lot easier at the Hi-CIRRF level. A functional-cycle-accurate simulation of the generated code would be feasible at the Lo-CIRRF level. The macros in Hi-CIRRF are used to:

- Instantiate and access buffers.
- Indicate pipelining and clock-cycle level hardware timing constraints. For example: imply back-end to instantiate registers to eliminate recurrence; enforce a pipeline delay for IP wrapper generation.
- Invoke hardware bitwise and arithmetic operations, such as bit-insert, bit-extract, and minimum of two values.
- Invoke hardware look-up tables and IP cores.

In Lo-CIRRF the code is similar to assembly code. It consists of a data and control flow graph with the following characteristics:

- Virtual statically single assigned registers.
- Register name indicates type (signed, unsigned) and bit size.
- Predicators of predication-guarded instructions and pipelining information of controller-controlled instructions.

3.1. Hi-CIRRF

The ROCCC system performs conventional loop transformations. It also carries out the following hardware-specific analysis and transformations.

Scalar replacement. The front-end decouples a do-all loop's array accesses from computation. Figure 2 (a) shows the original C code of a *gray scale transformation* example. After undergoing scalar replacement, the computation is isolated from memory accesses [Figure 2 (b)] by a smart buffer. The smart buffer will be synthesized on configurable fabrics as the interface with memory. One important characteristic of smart buffers is that they reuse input data between iterations and push one iteration's input data initiatively to the data-path, rather than being accessed by the data-path [9]. For a 3x3 window sliding over a two-dimensional array, without the smart buffer, each pixel needs to be read nine times from memory, while a smart buffer reduces the memory access to three times. A smart buffer of an unrolled loop can save more memory access. The syntax of a two-dimensional smart buffer macro is:

```
smartbuffer2(input_array_name, address_index_1,
            address_index_2, scalar_1, offset_1_1, offset_1_2,
            scalar_2, offset_2_1, offset_2_2, ....);
```

For example, in the smart buffer macro in Figure 2 (b), the last three parameters (x4, 1, 1) stands for:

$$x4 = a[i+1][j+1];$$

The syntax of FIFO buffers is similar. Currently we have the following constraints on buffer macros. An array can only appear in at most one buffer macro. The *address indexes* of buffers are also the loop counters. The operator between an address index variable and the offset can only be either addition or subtraction.

<pre>for (i=0; i<62; ++i) { for(j=0; j<62; ++j) { sum = (a[i][j] + a[i][j+1]) +(a[i+1][j] + a[i+1][j+1]); if(sum > 170) b[i][j] = 255; else { if(sum < 85) b[i][j] = 0; else b[i][j] = 127; } } } (a)</pre>	<pre>for (i=0; i<62; ++i) { for(j=0; j<62; ++j) { smartbuffer2(a, i, j, x1, 0, 0, x2, 0, 1, x3, 1, 0, x4, 1, 1); sum = (x1 + x2) + (x3 + x4); if(sum > 170) tmp = 255; else { if(sum<85) tmp=0; else tmp = 127; } fifo2(b, i, j, tmp, 0, 0); } } (b)</pre>
---	--

(a) Original C code, it sums the gray scale values of a 2x2 window in the input image (array a), assigns one of three possible values to the pixel in the output image (array b) depending on the summation. (b) Intermediate C code emitted by front-end. The highlighted segments are created by scalar replacement.

Figure 2 – A gray scale transformation example in C

Feedback variable detection. The compiler detects scalar recurrence between adjacent iterations. For example, for a loop having a statement “ $sum = sum + a[ij]$ ”, to eliminate the loop-carried dependency, the compiler replaces the *sum* on the left and the *sum* on the right with *store2next()* macro and *load_previous()* macro, respectively. These macros guide the back-end to instantiate a feedback register to store the current *sum* for the next iteration, and consequently transform the loop to a do-all-loop.

The output from the front-end is in the forms of both an IR file and an intermediate C with macros. Users could do further optimizations and add pragmas onto the intermediate C.

3.2. Lo-CIRRF

Starting from a conventional CFG, the compiler finds loops and loop-depth. Loop types are recorded in the IR by recovering them from user-added pragmas: Currently, these include one-dimensional do-all loop, two-dimensional perfect nested do-all loop, and non-do-all loop. The pre-process phase of the back-end converts macros in Hi-CIRRF into corresponding instructions. Particularly, buffer macros are converted into buffer instructions and put into separated nodes.

We categorize basic nodes into two types: do-all nodes and non-do-all nodes. Lo-CIRRF records different data-flow and scheduling information accordingly.

3.2.1. Building Lo-CIRRF for do-all nodes

For a do-all loop, Lo-CIRRF provides field to exploit both instruction-level and loop-level parallelisms. The compiler performs if-converse in a way that any node has at most two predecessors.

In order to allow the data-path to execute multiple loops simultaneously, the IR has a “execution level” field for each instruction inside a do-all node so that each level is an instantiation of one iteration. Statically single assigned

```

flag = 1;
for (m = 0; m < 10; m = m + 1) {
  if(flag == 1) {
    for(i = 1; i < 251; i = i + 1)
      b[i]=(3*a[i-1]+5*a[i])+(7*a[i+1]+9*a[i+2])+11*a[i+3]; }
    else {
      for(j = 1; j < 251; j = j + 1)
        d[j]=(3*c[j-1]+5*c[j])+(7*c[j+1]+9*c[j+2])+11*c[j+3]; }
    flag = flag ^ 1;
  }
return; }

```

The first highlighted segment is a 5-tap FIR reading array *a* and writing array *b*, while the second highlighted segment is a 5-tap FIR reading array *c* and writing array *d*. *flag* switches the execution of these two segments alternatively. The two inner loops are do-all loops, while the outer loop (the one with loop counter *m*) is not.

Figure 3 – An alternative FIR example in C

variables are added by the compiler to duplicate a variable if that variable’s definition reaches more than one level of execution lower. Thereby, any variable’s definition is always one execution level higher. Multiplexers are added, and speculators are duplicated and propagated along with execution levels. Notice that each execution level represents a single iteration at a given execution phase.

Lo-CIRRF provides another field, “pipeline stage” to record pipelining information. The instructions belonging to the same execution level are either all latched or all non-latched. Multiple consecutive execution levels may be assigned into the same pipeline stage. Having both execution level and pipeline stage separates data-flow building and pipelining, and provides compiler designers the opportunity to implement different pipelining strategies.

The compiler generates the smart buffers and output FIFOs in VHDL at compile time [9], as well as the data-paths [6].

3.2.2. Building Lo-CIRRF for non-do-all nodes

A non-do-all basic node either belongs to a non-do-all loop or does not belong to any loop at all. Multiple instructions might belong to the same execution level and can be executed simultaneously to exploit instruction level parallelism. Notice that for a non-do-all basic node, at most one iteration is executed at a time.

Lo-CIRRF has a predication field for each instruction to schedule the execution of non-do-all nodes. Each pipeline stage is guarded by a predicator. The format is:

```
ADD $vr4, $vr3, $vr2, $vr1
```

vr4 is the destination operand and *vr3* and *vr2* are the source operands. *vr1* is the predicator, which is also a source operand. Predicators are passed inside basic nodes for scheduling purpose. A special instruction, *PFW* (predicator forward), is used to pass a predicator from the current stage to the next stage, which may be or may not be in the same node:

```
PFW $vr2.u1, $vr1.u1
```

vr1 and *vr2* are two predicators. The instructions guarded by *vr2* are one pipeline stage later than the ones guarded by *vr1*. Their types are *u1*, which stands for unsigned one-bit.

The branch instructions of basic nodes are replaced by Boolean instructions, whose destination operands are evaluated by this basic node’s successor nodes.

Essentially, Lo-CIRRF describes a DFG, in which do-all loop nodes are connected together by non-do-all nodes. Then the compiler’s VHDL generator emits VHDL code for the entire DFG, including buffers, at compile time.

4. CASE STUDY

In this case study, besides reporting the synthesis results of the gray scale transformation example discussed in previous sections, we examine CIRRF on another application, an alternative finite impulse response filter

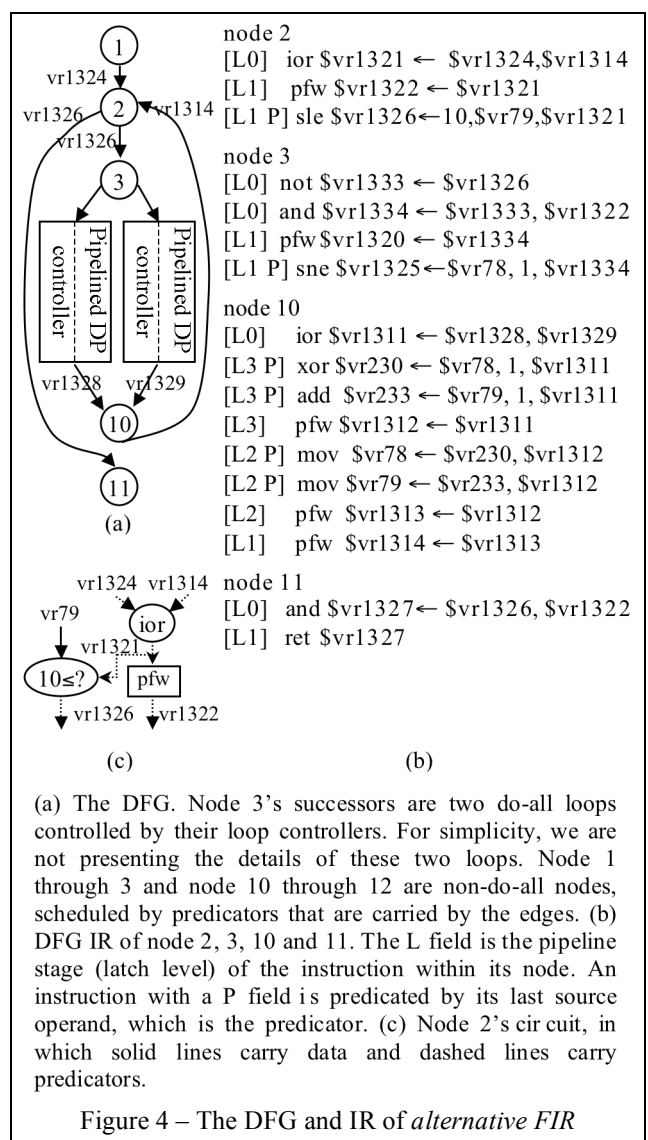

Figure 4 – The DFG and IR of alternative FIR

Table 1 - Synthesis results of case study examples

	DP-size (bit)	mem bus bit-size	# of slices	clock (MHz)	iter. per cycle
gray scale tran.	16	16	318	59.7	0.5
altern. FIR	8	8	531	100	1

(FIR).

Figure 3 shows the original C code. The two do-all inner loops (the two highlighted regions) are executed alternately. Each of these two inner loops is a 5-tap FIR.

Each FIR's loop body is aggressively pipelined, and the resulting data-path has a throughput of one iteration per clock cycle [Figure 4 (a)]. All the non-do-all nodes are predicated. We list the instructions of these nodes in Figure 4 (b). Node 2 and node 10 are the head and tail nodes of the outer loop, respectively. The first instruction of node 2, the *ior* instructions, produces the predicator (*vr1321*) for the two instructions below it (*pfw* and *sle*) by examining a valid output predicator from either node 1 (not shown), the first active node; or node 11, the loop tail. Figure 4 (c) depicts node 2's circuit in detail. Guarded by *vr1321*, the *sle* instruction asserts its destination operand when the outer loop is done, or de-asserts its destination operand when needing to execute a new outer loop iteration. Node 2's *pfw* instruction forwards a valid *vr1321* to the two successor nodes, node 3 and node 11, for their predicator evaluation. Node 3 enables one of the two FIRs by either asserting or de-asserting *vr1325*, depending the value of *flag* (*vr78*). Node 10 is activated by the *done* signal from one of the FIRs' loop controller and updates the value of *flag* (*vr230*) and the loop counter *m* (*vr233*). Node 11 indicates the completion of the whole procedure.

Table 1 shows the synthesis results of the gray scale transformation example discussed in previous sections and the alternative FIR. The targeting FPGA is Xilinx xc2v8000-5 with 46592 slices in total. The generated VHDL are synthesized and placed-and-routed using Xilinx ISE 6.2.03i. The second and the third columns are the data-path's bit-size and BRAM bus's bit-size. # of slices and clock rate are collected from place-and-route reports. The last column is the number of do-all loop iterations executed per clock cycle. For *gray scale transformation*, the resulting data flow is capable of executing one iteration every clock cycle. Notice we configure the BlockRAM's data bus (the third column) to have the same bit-size as that of the data elements (pixels), and every iteration needs four (2x2) pixels. Though the smart buffer reuses one column of the pixels loaded in the previous iteration, it still needs two cycles to load the remaining two new pixels. This explains the reason that for the *gray scale transformation* example, the number of iterations per cycle is 0.5. For the *alternative FIR*, when either one of the two do-all loops is active, the corresponding smart buffer exports one window of data (five elements) to the data-path every clock cycle, and therefore the circuit executes one iteration per cycle. #

of slices consists of the hardware of two do-all loops (including the data-path and controller for each FIR) and the hardware of the non-do-all nodes, as shown in Figure 4 (a).

5. CONCLUSION

We have presented CIRRF, an intermediate representation for compiling high-level languages to reconfigurable fabrics. CIRRF has two parts, Hi-CIRRF and Lo-CIRRF. Hi-CIRRF is essentially C with macros. The macros are used to record information associated with buffers, pipelining, look-up tables, special operations etc. Lo-CIRRF decomposes conventional CFGs into do-all loop nodes and non-do-all nodes. The loop body instructions of a do-all loop are placed into execution levels. Each execution level is an instantiation of one iteration at different execution phases. Lo-CIRRF provides a platform for the compiler to aggressively pipeline do-all loops. Non-do-all nodes are predicated in Lo-CIRRF and predicators are passed within and between nodes.

We have shown, through case studies, how CIRRF models the application examples and provides a solid foundation for the compiler to generate efficient hardware.

6. REFERENCES

- [1] M. B. Gokhale, J. M. Stone, J. Arnold, and M. Lalinowski. Stream-oriented FPGA computing in the Streams-C high level language. In IEEE Symp. on FPGAs for Custom Computing Machines (FCCM), 2000.
- [2] J. Tripp, K. Peterson, C. Ahrens, J. Poznanovic, M. Gokhale. Trident: An FPGA Compiler Framework for Floating-Point Algorithms, int. Conference on Field Programmable Logic and Applications (FPL 2005). Finland, 2005
- [3] The LLVM Compiler Infrastructure. <http://llvm.org/> 2006
- [4] W. Najjar, W. Böhm, B. Draper, J. Hammes, R. Rinker, R. Beveridge, M. Chawathe and C. Ross. From Algorithms to Hardware - A High-Level Language Abstraction for Reconfigurable Computing. IEEE Computer, August 2003.
- [5] M. Budiu and S. C. Goldstein. Pegasus: An efficient intermediate representation. Technical Report CMU-CS-02-107, CMU, May 2002.
- [6] Z. Guo, B. Buyukkurt, W. Najjar and K. Vissers. Optimized Generation of Data-path from C Codes for FPGAs, Int. ACM/IEEE Design, Automation and Test in Europe Conference (DATE 2005). Munich, Germany, March, 2005.
- [7] SUIF Compiler System. <http://suif.stanford.edu>, 2006
- [8] Machine-SUIF. 2006 <http://www.eecs.harvard.edu/hube/research/machsuiif.html>
- [9] Z. Guo, B. Buyukkurt, W. Najjar. Input Data Reuse In Compiling Window Operations Onto Reconfigurable Hardware, Proc. ACM Symp. On Languages, Compilers and Tools for Embedded Systems (LCTES), Washington, DC, June 2004.