

---

# Chapter 5 – The Processor: Datapath and Control

# A single-cycle MIPS processor

---

- An instruction set architecture is an *interface* that defines the hardware operations which are available to software.
- Any instruction set can be implemented in many different ways. Over the next few weeks we'll see several possibilities.
  - In a basic **single-cycle implementation** all operations take the same amount of time—a single cycle.
  - A **multicycle implementation** allows faster operations to take less time than slower ones, so overall performance can be increased.
  - Finally, **pipelining** lets a processor overlap the execution of several instructions, potentially leading to big performance gains.

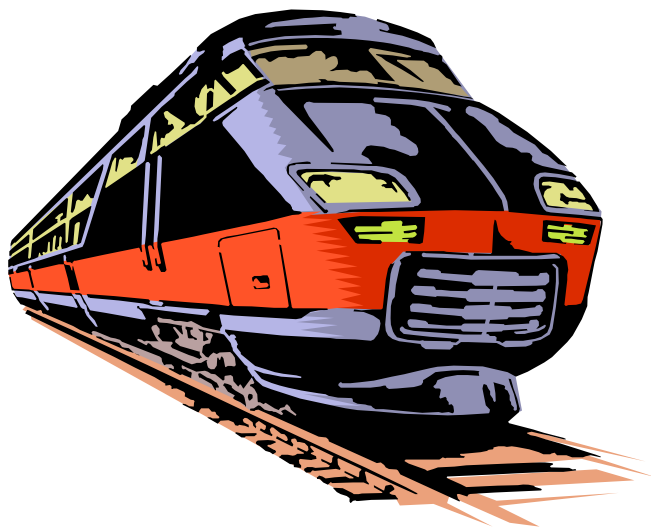

# Single-cycle implementation

---

- In lecture, we will describe the implementation a simple MIPS-based instruction set supporting just the following operations.

Arithmetic:	add	sub	and	or	slt
Data Transfer:	lw	sw			
Control:	beq				

- Today we'll build a **single-cycle implementation** of this instruction set.
  - All instructions will execute in the same amount of time; this will determine the clock cycle time for our performance equations.
  - We'll explain the datapath first, and then make the control unit.

# Computers are state machines

---

- A computer is just a big fancy **state machine**.
  - Registers, memory, hard disks and other storage form the state.
  - The processor keeps reading and updating the state, according to the instructions in some program.

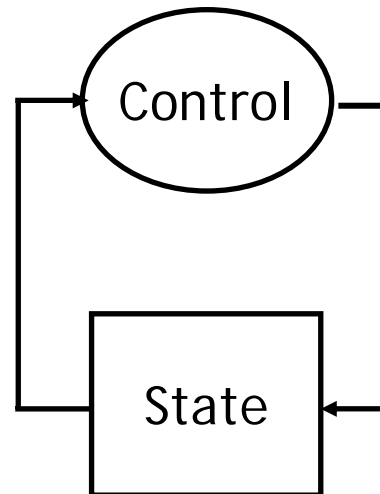

# John von Neumann

- In the old days, “programming” involved actually changing a machine’s physical configuration by flipping switches or connecting wires.
  - A computer could run just one program at a time.
  - Memory only stored data that was being operated on.
- Then around 1944, John von Neumann and others got the idea to encode instructions in a format that could be stored in memory just like data.
  - The processor interprets and executes instructions from memory.
  - One machine could perform many different tasks, just by loading different programs into memory.
  - The “stored program” design is often called a **Von Neumann machine**.



# Memories

- It's easier to use a **Harvard architecture** at first, with programs and data stored in *separate* memories.
- The dark lines here represent 32-bit values, so these are  $2^{32} \times 32$  memories.
- Blue lines represent control signals. **MemRead** and **MemWrite** should be set to 1 if the **data memory** is to be read or written respectively, and 0 otherwise.
  - When a control signal does something when it is set to 1, we call it **active high** (vs. active low) because 1 is usually a higher voltage than 0.
- For today, we will assume you cannot write to the **instruction memory**.
  - Pretend it's already loaded with a program, which doesn't change while it's running.

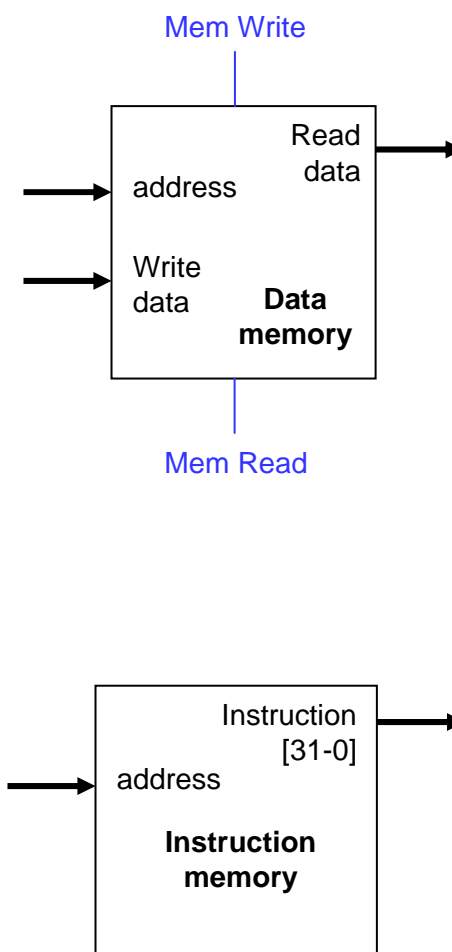

# Instruction fetching

- The CPU is always in an infinite loop, fetching instructions from memory and executing them.
- The **program counter** or **PC** register holds the address of the current instruction.
- MIPS instructions are each four bytes long, so the PC should be incremented by four to read the next instruction in sequence.

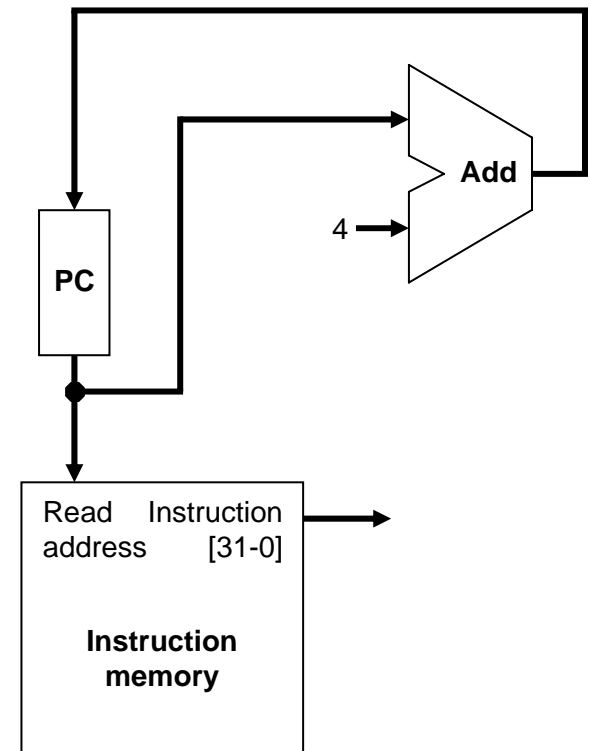

# Encoding R-type instructions

- A few weeks ago, we saw encodings of MIPS instructions as 32-bit values.
- Register-to-register arithmetic instructions use the **R-type** format.
  - **op** is the instruction opcode, and **func** specifies a particular arithmetic operation (see the back of the textbook).
  - **rs**, **rt** and **rd** are source and destination registers.

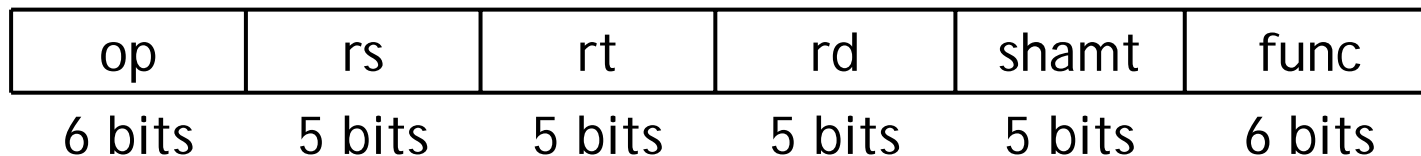

- An example instruction and its encoding:

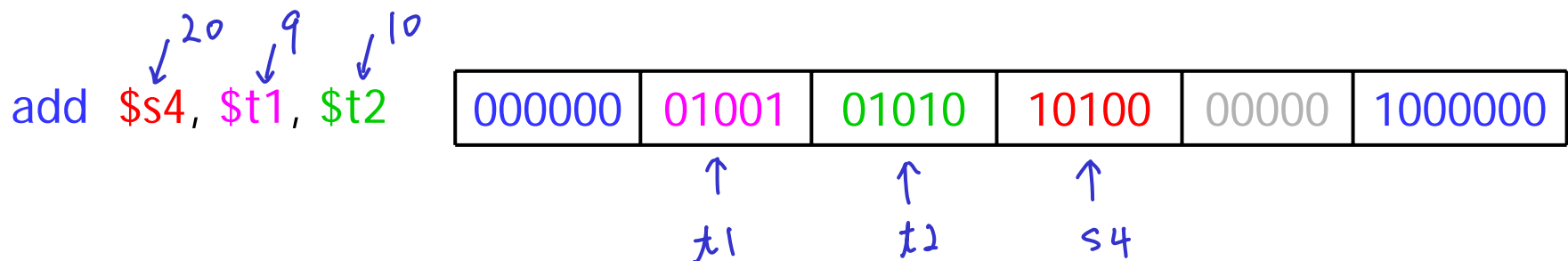

# Registers and ALUs

- R-type instructions must access registers and an ALU.
- Our **register file** stores thirty-two 32-bit values.
  - Each register specifier is 5 bits long.
  - You can read from two registers at a time (2 ports).
  - **RegWrite** is 1 if a register should be written.
- Here's a simple **ALU** with five operations, selected by a 3-bit control signal **ALUOp**.

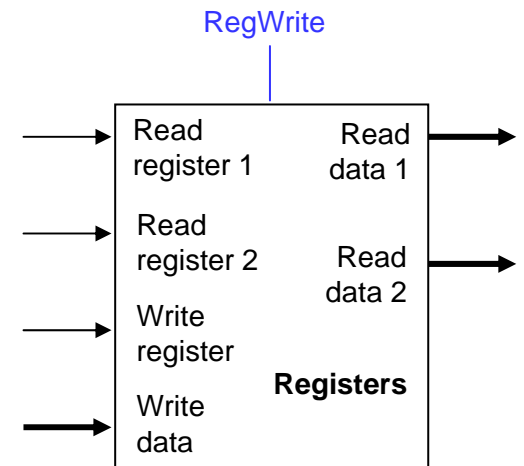

ALUOp	Function
000	and
001	or
010	add
110	subtract
111	slt

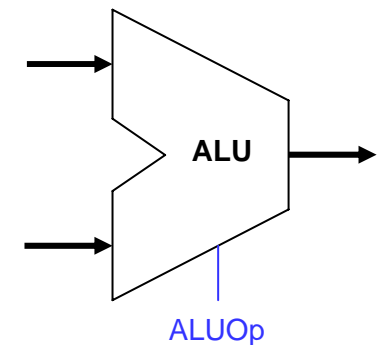

# Executing an R-type instruction

1. Read an instruction from the instruction memory.
2. The source registers, specified by instruction fields *rs* and *rt*, should be read from the register file.
3. The ALU performs the desired operation.
4. Its result is stored in the destination register, which is specified by field *rd* of the instruction word.

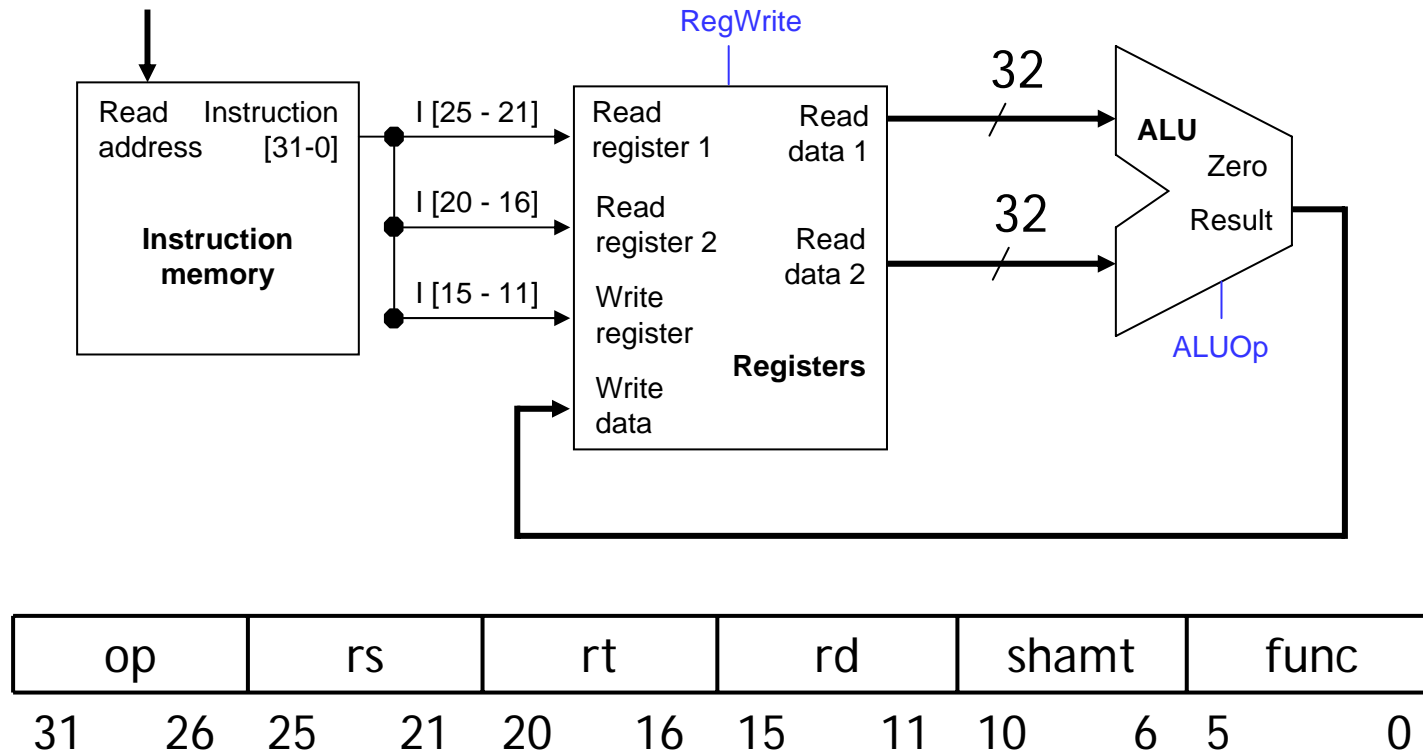

# Encoding I-type instructions

- The lw, sw and beq instructions all use the **I-type** encoding.
  - **rt** is the *destination* for lw, but a *source* for beq and sw.
  - **address** is a 16-bit signed constant.

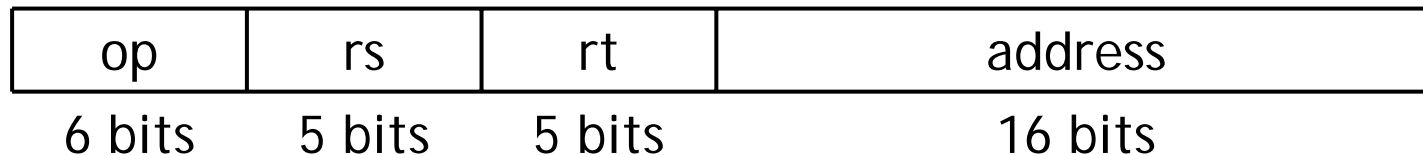

- Two example instructions:

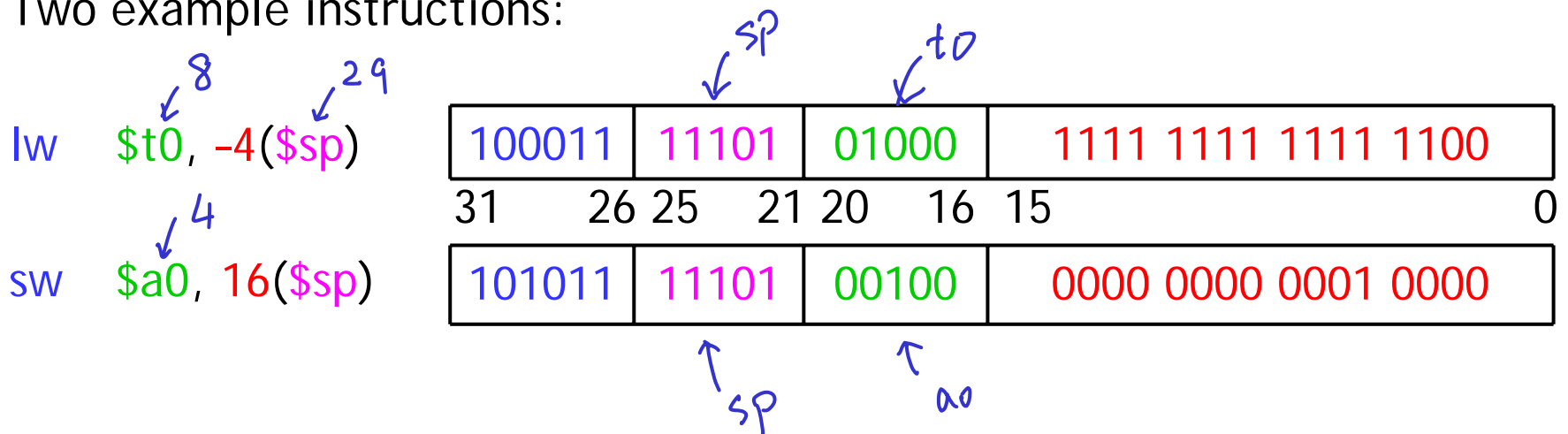

# Accessing data memory

- For an instruction like `lw $t0, -4($sp)`, the base register `$sp` is added to the *sign-extended* constant to get a data memory address.
- This means the ALU must accept *either* a register operand for arithmetic instructions, *or* a sign-extended immediate operand for `lw` and `sw`.
- We'll add a multiplexer, controlled by `ALUSrc`, to select either a register operand (0) or a constant operand (1).

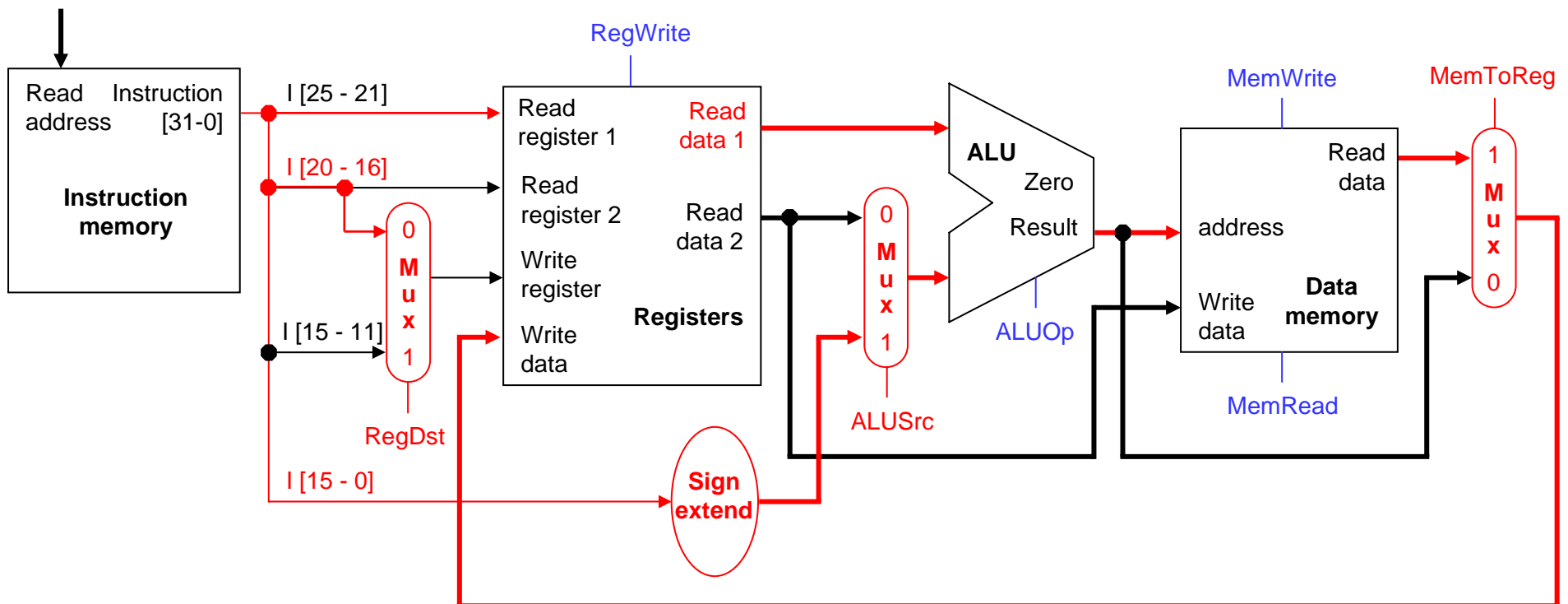

# Branches

- For branch instructions, the constant is not an address but an *instruction offset (or word offset)* from the *next* program counter to the desired address.

```
    beq  $at, $0, L
    add  $v1, $v0, $0
    add  $v1, $v1, $v1
    j    Somewhere
L:     add  $v1, $v0, $v0
```

- The target address L is three *instructions* past the first add, so the encoding of the branch instruction has 0000 0000 0000 0011 for the address field.

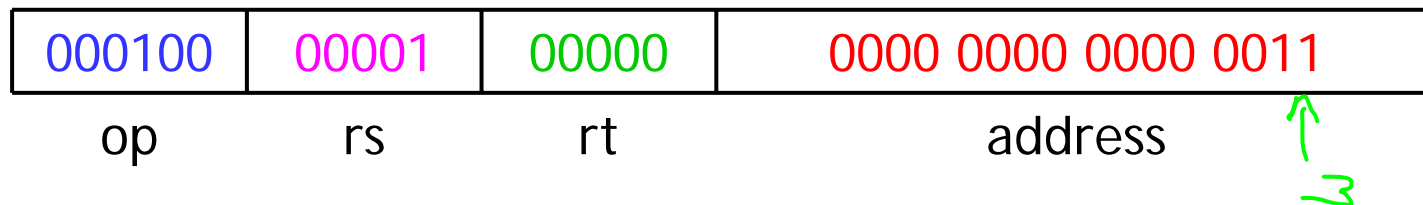

- Instructions are four bytes long, so the actual memory offset is 12 bytes.

# The steps in executing a beq

---

1. Fetch the instruction, like `beq $at, $0, offset`, from memory.
2. Read the source registers, `$at` and `$0`, from the register file.
3. Compare the values by subtracting them in the ALU.
4. If the subtraction result is 0, the source operands were equal and the PC should be loaded with the target address,  $PC + 4 + (\text{offset} \times 4)$ .
5. Otherwise the branch should not be taken, and the PC should just be incremented to  $PC + 4$  to fetch the next instruction sequentially.

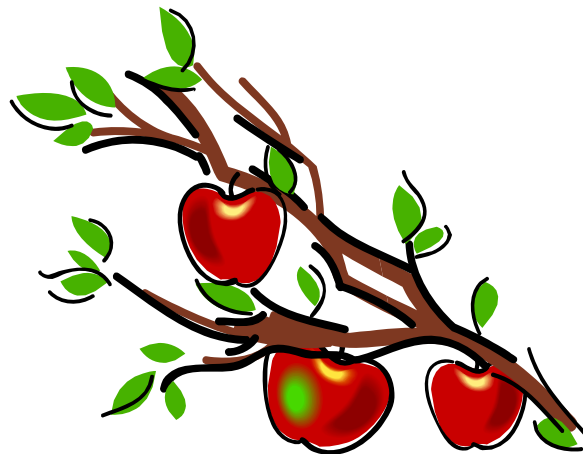

# Branching hardware

We need a second adder, since the ALU is already doing subtraction for the beq.

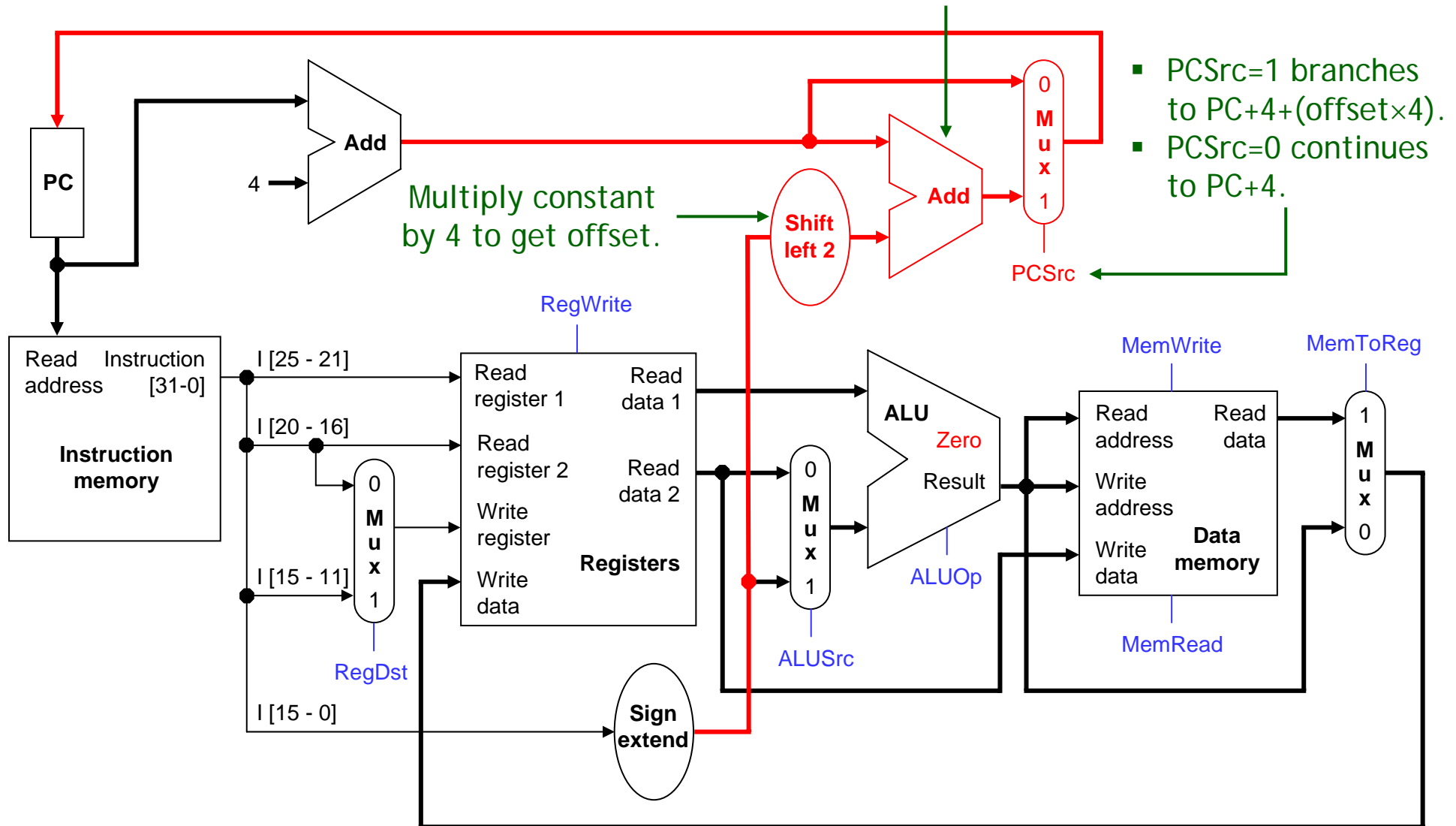

# The final datapath

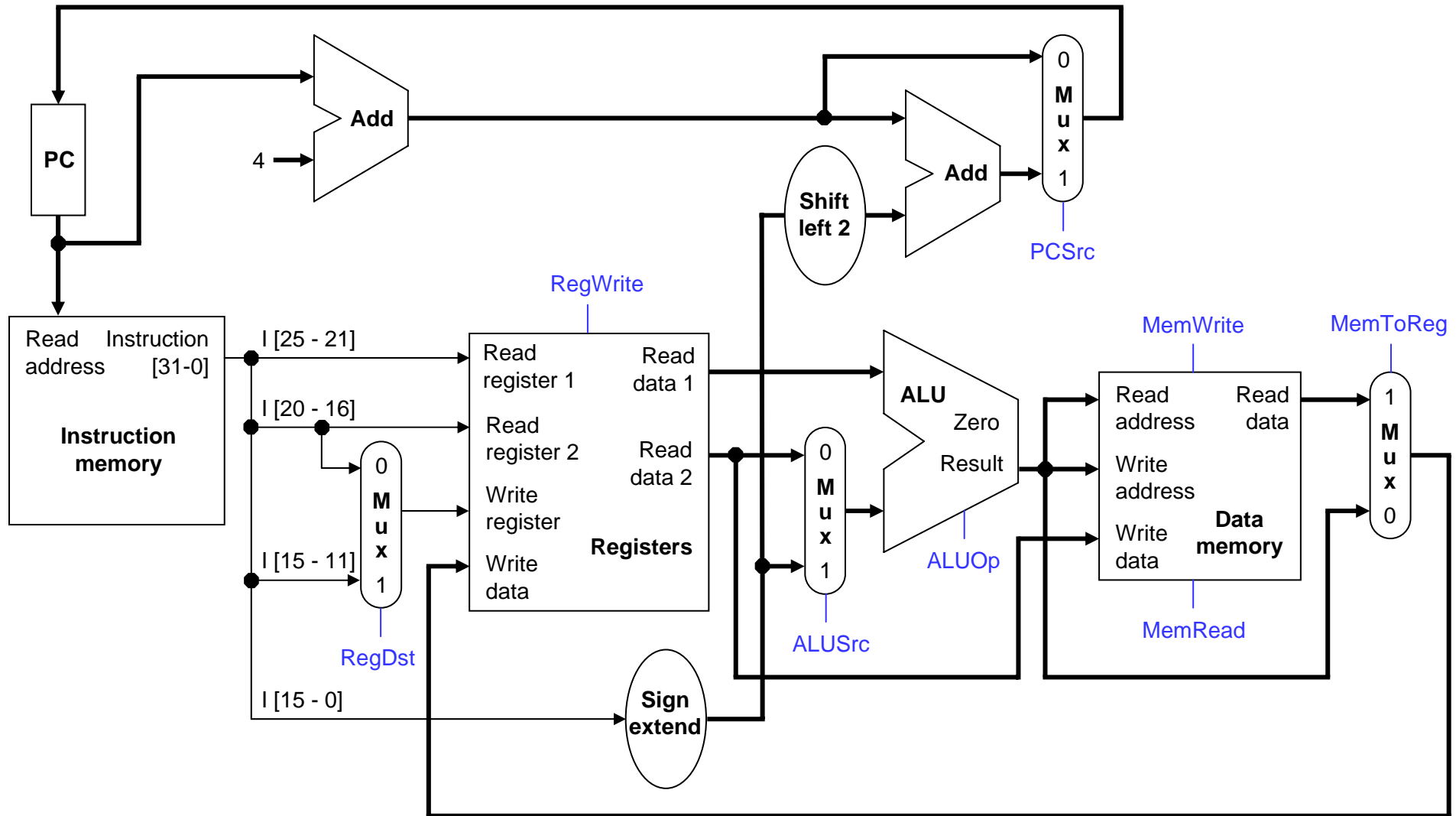

# Control

---



- The **control unit** is responsible for setting all the control signals so that each instruction is executed properly.
  - The control unit's input is the 32-bit instruction word.
  - The outputs are values for the blue control signals in the datapath.
- Most of the signals can be generated from the instruction **opcode** alone, and not the entire 32-bit word.
- To illustrate the relevant control signals, we will show the route that is taken through the datapath by R-type, lw, sw and beq instructions.

# R-type instruction path

- The R-type instructions include `add`, `sub`, `and`, `or`, and `slt`.
- The `ALUOp` is determined by the instruction's "func" field.

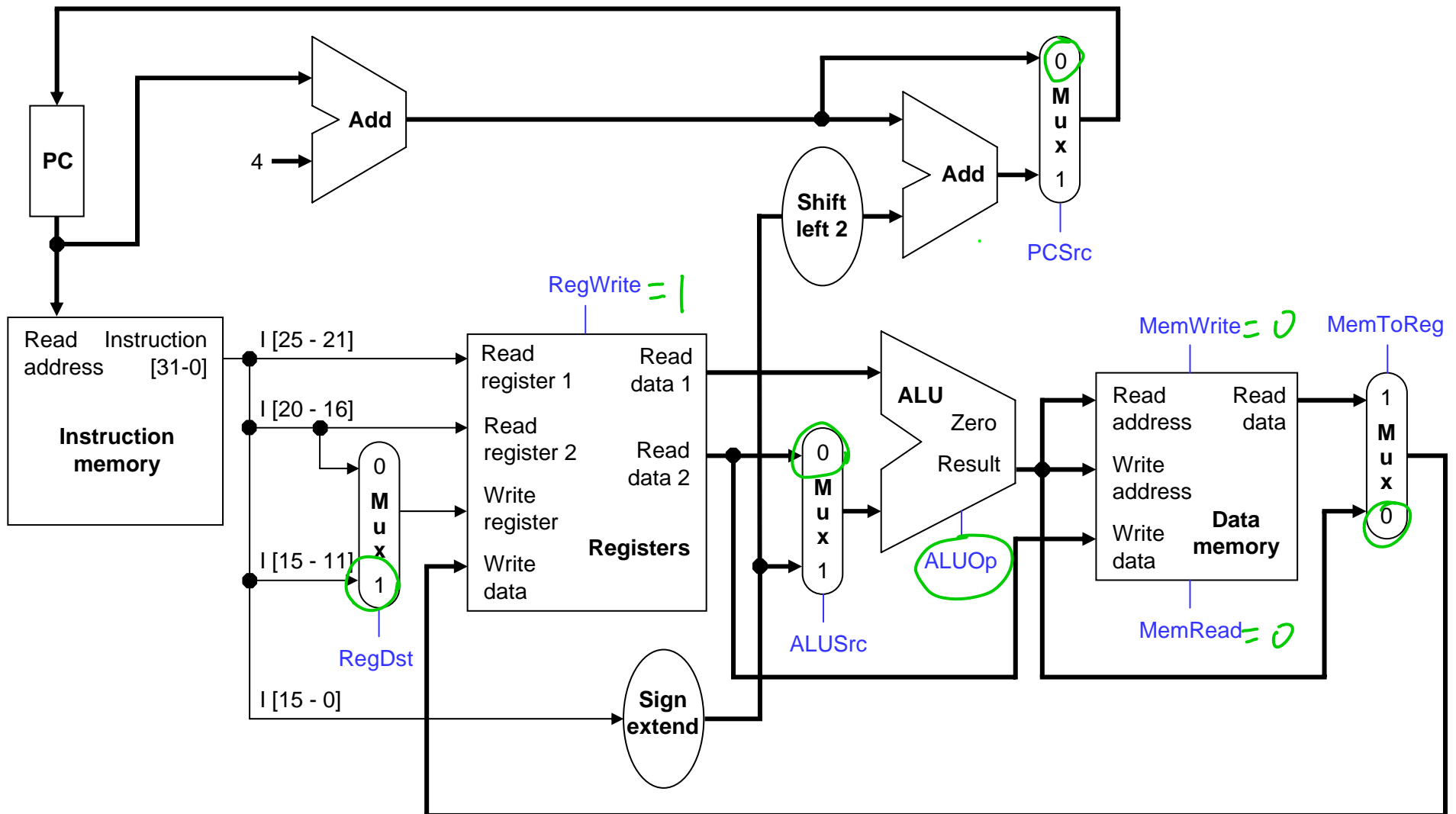

# lw instruction path

- An example load instruction is `lw $t0, -4($sp)`.
- The `ALUOp` must be 010 (add), to compute the effective address.

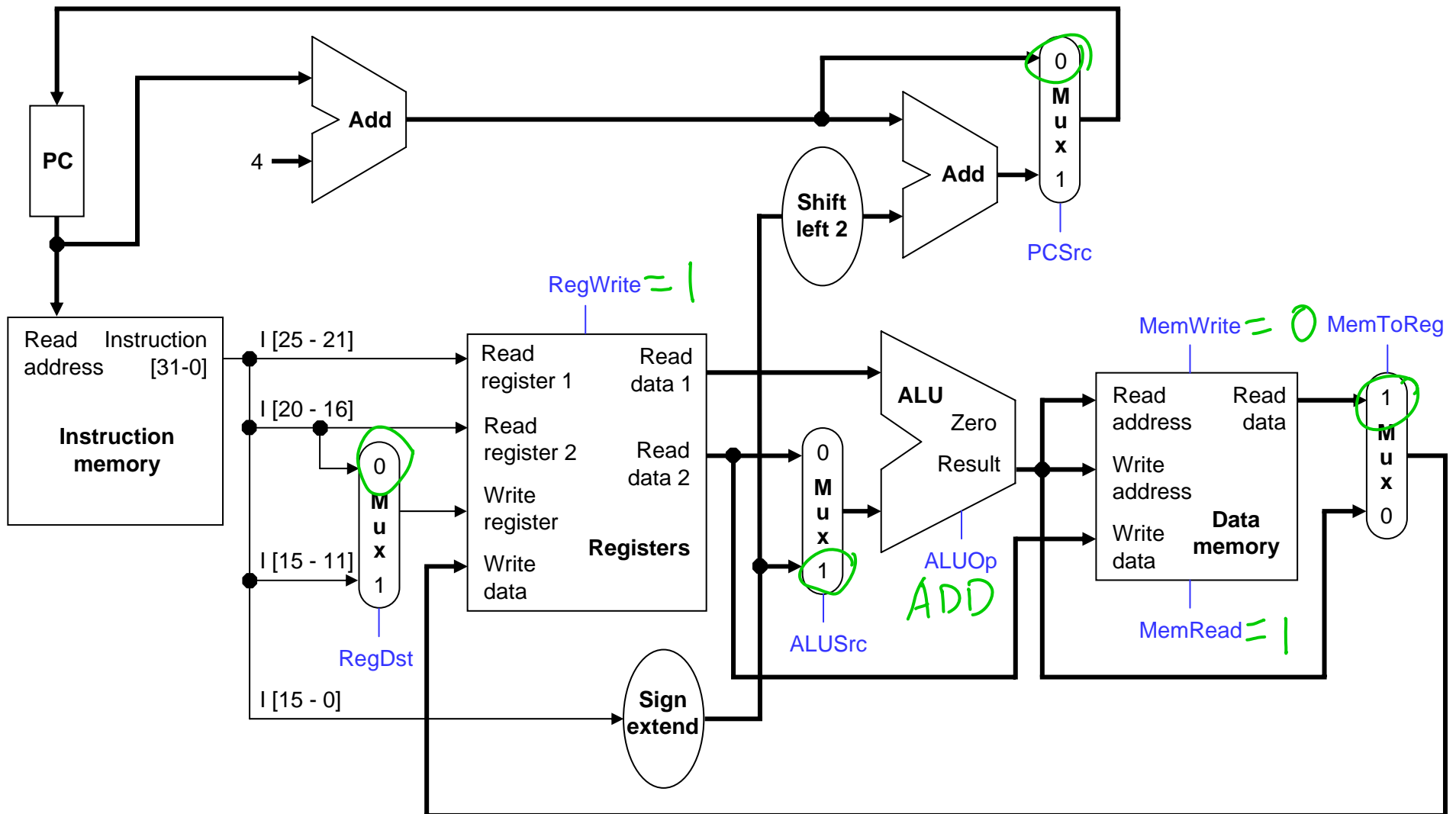

# sw instruction path

- An example store instruction is `sw $a0, 16($sp)`.
- The `ALUOp` must be 010 (add), again to compute the effective address.

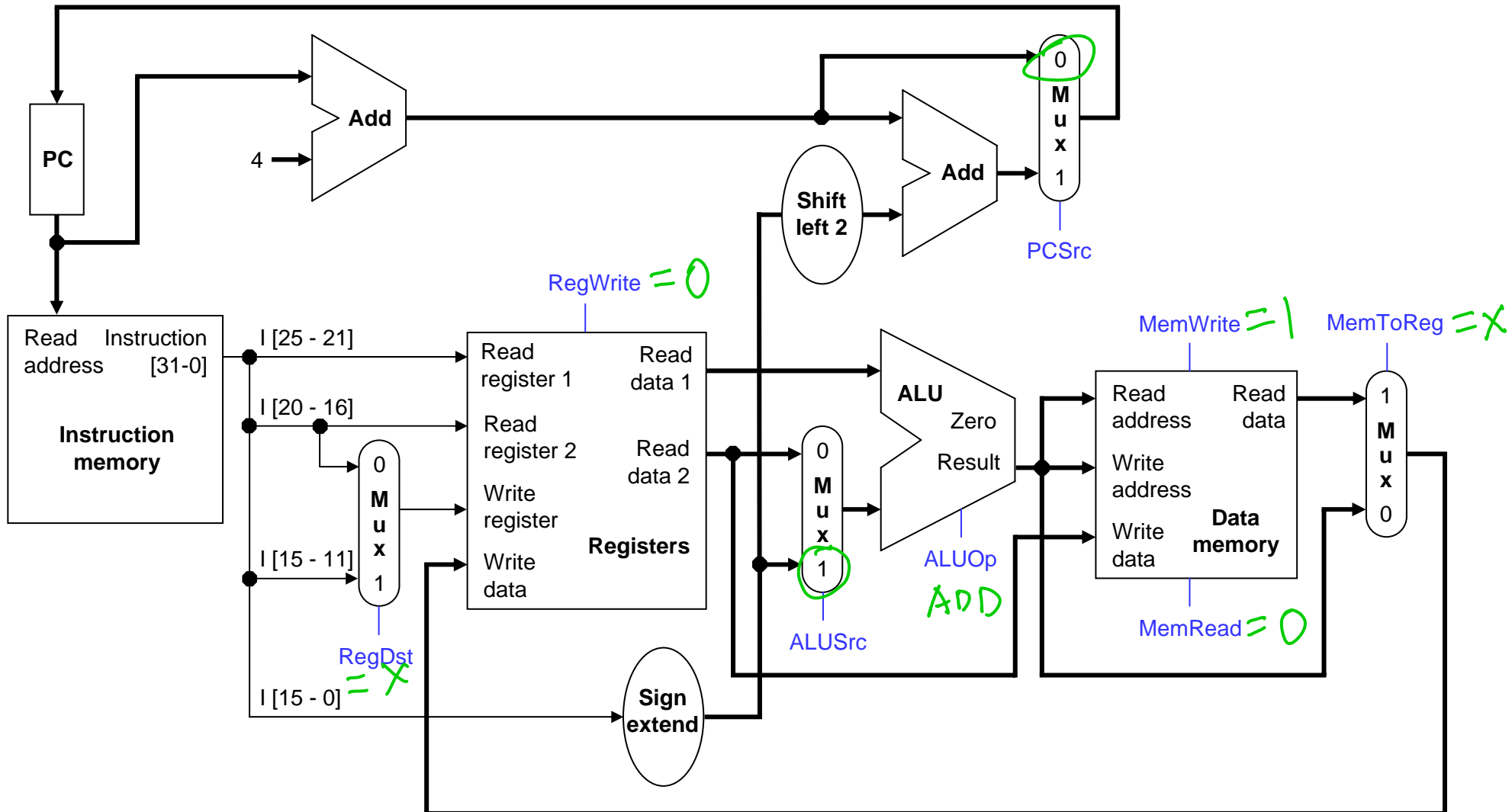



# Control signal table

Operation	RegDst	RegWrite	ALUSrc	ALUOp	MemWrite	MemRead	MemToReg
add	1	1	0	010	0	0	0
sub	1	1	0	110	0	0	0
and	1	1	0	000	0	0	0
or	1	1	0	001	0	0	0
slt	1	1	0	111	0	0	0
lw	0	1	1	010	0	1	1
sw	X	0	1	010	1	0	X
beq	X	0	0	110	0	0	X

- **sw and beq are the only instructions that do not write any registers.**
- **lw and sw are the only instructions that use the constant field. They also depend on the ALU to compute the effective memory address.**
- **ALUOp for R-type instructions depends on the instructions' func field.**
- The PCSrc control signal (not listed) should be set if the instruction is beq *and* the ALU's Zero output is true.

# Generating control signals

- The control unit needs 13 bits of inputs.
  - Six bits make up the instruction's opcode.
  - Six bits come from the instruction's func field.
  - It also needs the Zero output of the ALU.
- The control unit generates 10 bits of output, corresponding to the signals mentioned on the previous page.
- You can build the actual circuit by using big Boolean algebra, or big circuit design programs.

